

# CERTIFICATE



## CERTIFICATE Of Conformity EU Council Directive 2014/30/EU Electromagnetic Compatibility

Registration No.: **ATZALE180807001**

Report No.: **SZALE180807001-01**

Applicant : **Ledlenser Corporation Ltd.**

No.25, Yudong 1 Road, Dongcheng Town, Yangdong District,  
Yangjiang City, GD, 529931, China

Product : **Flashlight**

Identification : Model No. : **EX7R**

Trade Mark :  **LEDLENSER**

Rating : Input: DC 19V, 2.1A(Adapter)  
Output: 3.6V, 11.7Wh  
Capacity: 3250mAh(Battery)

Test Standards : EN 55015: 2013+A1: 2015  
EN 61000-3-2: 2014  
EN 61000-3-3: 2013  
EN 61547: 2009

The certificate of conformity is based on an evaluation of a sample of the above-mentioned product. Technical report and documentation are at the applicant's disposal. This is to certify that the tested sample is in conformity with all provisions of Annex II of Council Directive 2014/30/EU, in its latest amended version, referred to EMC Directive. The certificate does not imply assessment of the production and does not permit the use of Lab's logo. The applicant of the certificate is authorized to use this certificate in connection with EU declaration of conformity to Article 15 of the Directive.



Certified by

Tom Chen  
Manager

Aug. 16, 2018  
Date



The CE Marking may only be used if all relevant and effective EU Directives are complied with



**Shenzhen Anbotek Compliance Laboratory Limited**

1/F, Building D, Sogood Science and Technology Park, Sanwei community,  
Hangcheng Street, Bao'an District, Shenzhen, Guangdong, China.518102

Tel: (86)755-26066440

Fax: (86)755-26014772

Http://[www.anbotek.com](http://www.anbotek.com)

Email: [service@anbotek.com](mailto:service@anbotek.com)



中国认可  
国际互认  
检测  
TESTING  
CNAS L3503

# EMC Test Report

For

Ledlenser Corporation Ltd.

Flashlight

Model No.: EX7R

Prepared For : Ledlenser Corporation Ltd.  
Address : No.25, Yudong 1 Road, Dongcheng Town, Yangdong District, Yangjiang  
City, GD, 529931, China

Prepared By : Shenzhen Anbotek Compliance Laboratory Limited  
Address : 1/F, Building D, Sogood Science and Technology Park, Sanwei  
community, Hangcheng Street, Bao'an District, Shenzhen, Guangdong,  
China.518102

Tel: (86) 755-26066440 Fax: (86) 755-26014772

Report Number : SZALE180807001-01

Date of Receipt : Aug. 07, 2018

Date of Test : Aug. 07~16, 2018

Date of Report : Aug. 16, 2018

# Contents

1. General Information.....	5
1.1. Client Information.....	5
1.2. Description of Device (EUT).....	5
1.3. Auxiliary Equipment Used During Test.....	5
1.4. Description of Test Modes.....	6
1.5. Test Summary.....	6
1.6. Test Equipment List.....	7
1.7. Description of Test Facility.....	9
1.9. EMS Performance Criteria.....	9
2. Power Line Conducted Emission Test.....	10
2.1. Test Standard and Limit.....	10
2.2. Test Setup.....	10
2.3. EUT Configuration on Measurement.....	10
2.4. Operating Condition of EUT.....	10
2.5. Test Procedure.....	11
2.6. Test Results.....	11
3. Radiated Emission Test.....	14
3.1. Test Standard and Limit.....	14
3.2. Test Setup.....	14
3.3. EUT Configuration on Measurement.....	14
3.4. Operating Condition of EUT.....	15
3.5. Test Procedure.....	15
3.6. Test Results.....	15
4. Magnetic Radiated Emission Test.....	20
4.1. Test Standard and Limit.....	20
4.2. Test Setup.....	20
4.3. EUT Configuration on Measurement.....	20
4.4. Operating Condition of EUT.....	20
4.5. Test Procedure.....	21
4.6. Test Results.....	21
5. Harmonic Current Emission Test.....	25
5.1. Test Standard.....	25
5.2. Test Setup.....	25
5.3. Operating Condition of EUT.....	25
5.4. Test Results.....	25
6. Voltage Fluctuations & Flicker Test.....	26
6.1. Test Standard.....	26
6.2. Test Setup.....	26
6.3. Operating Condition of EUT.....	26
6.4. Test Results.....	26
7. Electrostatic Discharge Immunity Test.....	28
7.1. Test Standard and Level.....	28
7.2. Test Setup.....	28

7.3. EUT Configuration on Measurement.....	28
7.4. Operating Condition of EUT.....	28
7.5. Test Procedure.....	29
7.6. Test Results.....	29
8. RF Field Strength Susceptibility Test.....	31
8.1. Test Standard and Level.....	31
8.2. Test Setup.....	31
8.3. EUT Configuration on Measurement.....	32
8.4. Operating Condition of EUT.....	32
8.5. Test Procedure.....	32
8.6. Measuring Results.....	32
9. Electrical Fast Transient/Burst Immunity Test.....	34
9.1. Test Standard and Level.....	34
9.2. Test Setup.....	34
9.3. EUT Configuration on Measurement.....	34
9.4. Operating Condition of EUT.....	34
9.5. Test Procedure.....	35
9.6. Test Results.....	35
10. Surge Immunity Test.....	37
10.1. Test Standard and Level.....	37
10.2. Test Setup.....	37
10.3. EUT Configuration on Measurement.....	37
10.4. Operating Condition of EUT.....	37
10.5. Test Procedure.....	38
10.6. Test Results.....	38
11. Injected Currents Susceptibility Test.....	40
11.1. Test Standard and Level.....	40
11.2. Test Setup.....	40
11.3. EUT Configuration.....	40
11.4. Operating Condition of EUT.....	40
11.5. Test Procedure.....	41
11.6. Test Results.....	41
12. Voltage Dips And Interruptions Test.....	43
12.1. Test Standard and Level.....	43
12.2. Test Setup.....	43
12.3. EUT Configuration on Measurement.....	43
12.4. Operating Condition of EUT.....	43
12.5. Test Procedure.....	44
12.6. Test Results.....	44
APPENDIX I -- TEST SETUP PHOTOGRAPH.....	46
APPENDIX II -- EXTERNAL PHOTOGRAPH.....	54

# TEST REPORT

Applicant : Ledlenser Corporation Ltd.  
Manufacturer : Ledlenser Corporation Ltd.  
Product Name : Flashlight  
Model No. : EX7R

Trade Mark : 

Rating(s) : Input: DC 19V, 2.1A(Adapter)  
Output: 3.6V, 11.7Wh  
Capacity: 3250mAh(Battery)

**Test Standard(s) : EN 55015: 2013+A1: 2015;  
EN 61000-3-2: 2014;  
EN 61000-3-3: 2013;  
EN 61547: 2009;  
(IEC 61000-4-2; IEC 61000-4-3; IEC 61000-4-4;  
IEC 61000-4-5; IEC 61000-4-6; IEC 61000-4-11)**

The device described above is tested by Shenzhen Anbotek Compliance Laboratory Limited to determine the maximum emission levels emanating from the device and the severe levels of the device can endure and its performance criterion. The measurement results are contained in this test report and Shenzhen Anbotek Compliance Laboratory Limited is assumed full responsibility for the accuracy and completeness of these measurements. Also, this report shows that the EUT to be technically compliant with the EN 55015, EN 61000-3-2, EN 61000-3-3 and EN 61547 requirements.

This report applies to above tested sample only and shall not be reproduced in part without written approval of Shenzhen Anbotek Compliance Laboratory Limited.

Date of Test: Aug. 07~16, 2018

Prepared By:



*Lucy Xu*

(Engineer / Lucy Xu)

Reviewer:

*Well Wang*

(Supervisor / Well Wang)

Approved & Authorized Signer:

*Tom Chen*

(Manager / Tom Chen)

## 1. General Information

### 1.1. Client Information

Applicant	:	Ledlenser Corporation Ltd.
Address	:	No.25, Yudong 1 Road, Dongcheng Town, Yangdong District, Yangjiang City, GD, 529931, China
Manufacturer	:	Ledlenser Corporation Ltd.
Address	:	No.25, Yudong 1 Road, Dongcheng Town, Yangdong District, Yangjiang City, GD, 529931, China
Factory	:	Ledlenser Corporation Ltd.
Address	:	No.25, Yudong 1 Road, Dongcheng Town, Yangdong District, Yangjiang City, GD, 529931, China

### 1.2. Description of Device (EUT)

Product Name	:	Flashlight
Model No.	:	EX7R
Trade Mark	:	
Test Power Supply	:	DC 19V via adapter AC 230V, 50Hz / DC 3.6V
Test Sample No.	:	S1
Product Description	:	Adapter: Manufacturer: PHIHONG TECHNOLOGY CO.,LTD. Model: PSA40W-190 INPUT: 100-240VAC, 50/60Hz, 1.0A OUTPUT: DC19V, 2.1A
<b>Remark:</b> (1) For a more detailed features description, please refer to the manufacturer's specifications or the User's Manual.		

### 1.3. Auxiliary Equipment Used During Test

N/A	
-----	--

### 1.4. Description of Test Modes

Pretest Modes	Descriptions
Mode 1	Charging
Mode 2	On

For Mode 1 Block Diagram of Test Setup

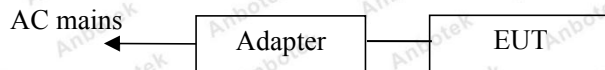

For Mode 2 Block Diagram of Test Setup



### 1.5. Test Summary

Test Items	Test Modes	Status
Power Line Conducted Emission Test (9KHz To 30MHz)	Mode 1	P
Radiated Emission Test (30MHz To 300MHz)	All Mode	P
Magnetic Radiated Emission Test (9KHz To 30MHz)	Mode 2	P
Harmonic Current Test	/	N
Voltage Fluctuations and Flicker Test	Mode 1	P
Electrostatic Discharge immunity Test	All Mode	P
RF Field Strength susceptibility Test	All Mode	P
Electrical Fast Transient/Burst Immunity Test	Mode 1	P
Surge Immunity Test	Mode 1	P
Injected Currents Susceptibility Test	Mode 1	P
Voltage Dips and Interruptions Test	Mode 1	P
P) Indicates that the through the test. N) Don't test.		

## 1.6. Test Equipment List

### Conducted Emission Measurement

Item	Equipment	Manufacturer	Model No.	Serial No.	Last Cal.	Cal. Interval
1.	L.I.S.N. Artificial Mains Network	Rohde & Schwarz	ENV216	100055	Nov. 17, 2017	1 Year
2.	EMI Test Receiver	Rohde & Schwarz	ESCI	100627	Nov. 17, 2017	1 Year
3.	RF Switching Unit	Compliance Direction	RSU-M2	38303	Nov. 17, 2017	1 Year
4.	Software Name EZ-EMC	Ferrari Technology	ANB-03A	N/A	N/A	N/A

### Radiated Emission Measurement

Item	Equipment	Manufacturer	Model No.	Serial No.	Last Cal.	Cal. Interval
1.	EMI Test Receiver	Rohde & Schwarz	ESCI	100627	Nov. 17, 2017	1 Year
2.	Bilog Broadband Antenna	Schwarzbeck	VULB9163	VULB 9163-289	Nov. 20, 2017	1 Year
3.	Pre-amplifier	SONOMA	310N	186860	Nov. 17, 2017	1 Year
4.	Software Name EZ-EMC	Ferrari Technology	ANB-03A	N/A	N/A	N/A

### Magnetic Radiated Emission Measurement

Item	Equipment	Manufacturer	Model No.	Serial No.	Last Cal.	Cal. Interval
1.	EMI Test Receiver	Rohde & Schwarz	ESCI	100627	Nov. 17, 2017	1 Year
2.	Triple-Loop Antenna(2M)	EVERFINE	LLA-2	905003	Nov. 17, 2017	1 Year
3.	RF Switching Unit	Compliance Direction	RSU-M2	38303	Nov. 17, 2017	1 Year
4.	Software Name EZ-EMC	Ferrari Technology	ANB-03A	N/A	N/A	N/A

### Harmonic and Flicker Measurement

Item	Equipment	Manufacturer	Model No.	Serial No.	Last Cal.	Cal. Interval
1.	Programmable AC Power source	IVYTECH	APS-5005A	632734	June 15, 2018	1 Year
2.	Harmonic and Flicker Analyzer	EMC-PARTNER	HRRMOINCS -1000-1P	164	Dec. 16, 2017	1 Year
3.	Harmonics-1000	N/A	Ed.3.0+4.0	N.A	N/A	N/A

### Electrostatic Discharge Measurement

Item	Equipment	Manufacturer	Model No.	Serial No.	Last Cal.	Cal. Interval
1.	ESD Simulators	3Ctest	ESD-30T	ES0131505	Nov. 17, 2017	1 Year

R/S Immunity Measurement

Item	Equipment	Manufacturer	Model No.	Serial No.	Last Cal.	Cal. Interval
1	RF Power Meter. Dual Channel	BOONTON	4232A	10539	May 19, 2018	1 year
2	50ohm Diode Power Sensor	BOONTON	51011EMC	34236/36164	May 19, 2018	1 year
3	Broad-Band Horn Antenna	SCHWARZBECK	BBHA9120 L3F	332	May 19, 2018	1 year
4	Power Amplifier (0.08-1G)	MILMEGA	80RF1000-175	1059345	May 19, 2018	1 year
5	Power Amplifier (1-2G)	MILMEGA	AS0102-55	1018770	May 19, 2018	1 year
6	Power Amplifier (2-6G)	MILMEGA	AS1860-50	1059346	May 19, 2018	1 year
7	Signal Generator	Agilent	N5181A	MY50145187	May 19, 2018	1 year
8	Field Strength Meter	HOLADAY	HI-6005	N/A	May 19, 2018	1 year
9	RS232 Fiber Optic Modem	HOLADAY	HI-4413P	N/A	May 19, 2018	1 year
10	Log.-Per. Antenna	SCHWARZBECK	VULP 9118E	N/A	May 19, 2018	1 year

**Remark:** This test item is subcontracted to Shenzhen EMTEK Co., Ltd.

Electrical Fast Transient/Burst Immunity Measurement

Item	Equipment	Manufacturer	Model No.	Serial No.	Last Cal.	Cal. Interval
1.1	EFT Burst Simulator	PRIMA	EFT61004B	PR10114282	Nov. 17, 2017	1 Year
1.2	EFT-Clamp	PRIMA	EFT-Clamp	/	Nov. 17, 2017	1 Year
2.1	EFT Burst Simulator	TESEQ	NSG 3060	1480	Nov. 17, 2017	1 Year
2.2	CDN	TESEQ	CDN 3061	1408	Nov. 17, 2017	1 Year

Surge Measurement

Item	Equipment	Manufacturer	Model No.	Serial No.	Last Cal.	Cal. Interval
1.1	6kV Surge Generator	TESEQ	NSG 3060	1480	Nov. 17, 2017	1 Year
1.2	CDN	TESEQ	CDN 3061	1408	Nov. 17, 2017	1 Year
2.1	6kV Surge Generator	EMPEK	LSG-5060G	06010017N	Nov. 17, 2017	1 Year
2.2	CDN	EMPEK	CDN-5110G	061100005N	Nov. 17, 2017	1 Year

Injected Currents Susceptibility Measurement

Item	Equipment	Manufacturer	Model No.	Serial No.	Last Cal.	Cal. Interval
1.	C/S Conducted Immunity Test System	FRANKONIA	CIT-10	126A1196/2012	Nov. 17, 2017	1 Year
2.	CDN	FRANKONIA	CDN - M2+ M3	A2210178/2012	Nov. 17, 2017	1 Year
3.	6dB Attenuator	FRANKONIA	DAM 26W	1172202	Nov. 17, 2017	1 Year
4.	CIT-10	FRANKONIA	Version1.1.7	N/A	N.A	N/A

Voltage Dips and Interruptions Measurement

Item	Equipment	Manufacturer	Model No.	Serial No.	Last Cal.	Cal. Interval
1.	CYCLE SAG Simulator	PRIMA	DRP61011AG	PR12046234	Nov. 17, 2017	1 Year

## 1.7. Description of Test Facility

The test facility is recognized, certified, or accredited by the following organizations:

### **FCC-Registration No.: 184111**

Shenzhen Anbotek Compliance Laboratory Limited, EMC Laboratory has been registered and fully described in a report filed with the (FCC) Federal Communications Commission. The acceptance letter from the FCC is maintained in our files. Registration No. 184111, July 31, 2017.

### **ISED-Registration No.: 8058A-1**

Shenzhen Anbotek Compliance Laboratory Limited, EMC Laboratory has been registered and fully described in a report filed with the (ISED) Innovation, Science and Economic Development Canada. The acceptance letter from the ISED is maintained in our files. Registration 8058A-1, June 13, 2016.

### **Test Location**

Shenzhen Anbotek Compliance Laboratory Limited.

1/F, Building D, Sogood Science and Technology Park, Sanwei community, Hangcheng Street, Bao'an District, Shenzhen, Guangdong, China.518102

## 1.9. EMS Performance Criteria

- √ A: Normal performance within the specification limits
- √ B: Temporary degradation or loss of function or performance which is self-recoverable
- √ C: Temporary degradation or loss of function or performance which requires operator intervention or system reset
- √ D: Degradation or loss of function which is not recoverable due to damage of equipment (components) or software, or loss of data

Note: The manufacturer's specification may define effects on the EUT which may be considered insignificant, and therefore acceptable.

This classification may be used as a guide in formulating performance criteria, by committees responsible for generic, product and product-family standards, or as a framework for the agreement on performance criteria between the manufacturer and the purchaser, for example where no suitable generic, product or product-family standard exists.

## 2. Power Line Conducted Emission Test

### 2.1. Test Standard and Limit

Test Standard	EN 55015
---------------	----------

Limits for conducted emissions

Test Limit	Frequency	At mains terminals (dB $\mu$ V)	
		Quasi-peak Level	Average Level
	9kHz ~ 50kHz	110	--
	50kHz ~ 150kHz	90 ~ 80*	--
	150kHz ~ 0.5MHz	66 ~ 56*	56 ~ 46*
	0.5MHz ~ 5.0MHz	56	46
	5.0MHz ~ 30MHz	60	50

**Remark:** (1) At the transition frequency the lower limit applies.  
(2) \* decreasing linearly with logarithm of the frequency.

### 2.2. Test Setup

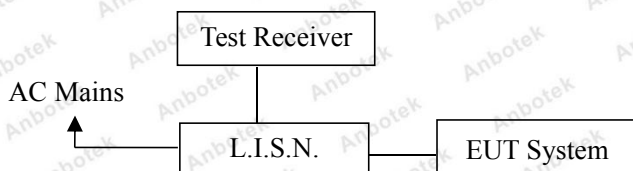

### 2.3. EUT Configuration on Measurement

The following equipments are installed on Conducted Emission Measurement to meet EN 55015 requirements and operating in a manner which tends to maximize its emission characteristics in a normal application.

### 2.4. Operating Condition of EUT

2.4.1. Setup the EUT as shown in Section 2.2.

2.4.2. Turn on the power of all equipments.

2.4.3. Let the EUT work in test mode and measure it.

## 2.5. Test Procedure

The EUT is put on the table which is 0.8 meter high above the ground and connected to the AC mains through a Line Impedance Stabilization Network (L.I.S.N.). This provided a 50ohm coupling impedance for the tested equipments. Both sides of AC line are checked to find out the maximum conducted emission according to the EN 55015 regulations during conducted emission measurement. And the voltage probe had been used for the load terminals measurement according to the EN 55015 standard.

The bandwidth of the test receiver (R&S ESCI) is set at 200Hz in 9K~150KHz range and 9KHz in 150K~30MHz range.

The frequency range from 9KHz to 30MHz is checked.

All the test results are listed in Section 2.6.

## 2.6. Test Results

**PASS**

The test curves are shown in the following pages.

**Conducted Emission Test Data**

Test Site: 1# Shielded Room  
 Test Specification: DC 19V via adapter AC 230V, 50Hz  
 Comment: Live Line  
 Temp.: 22.2°C Hum.: 60%

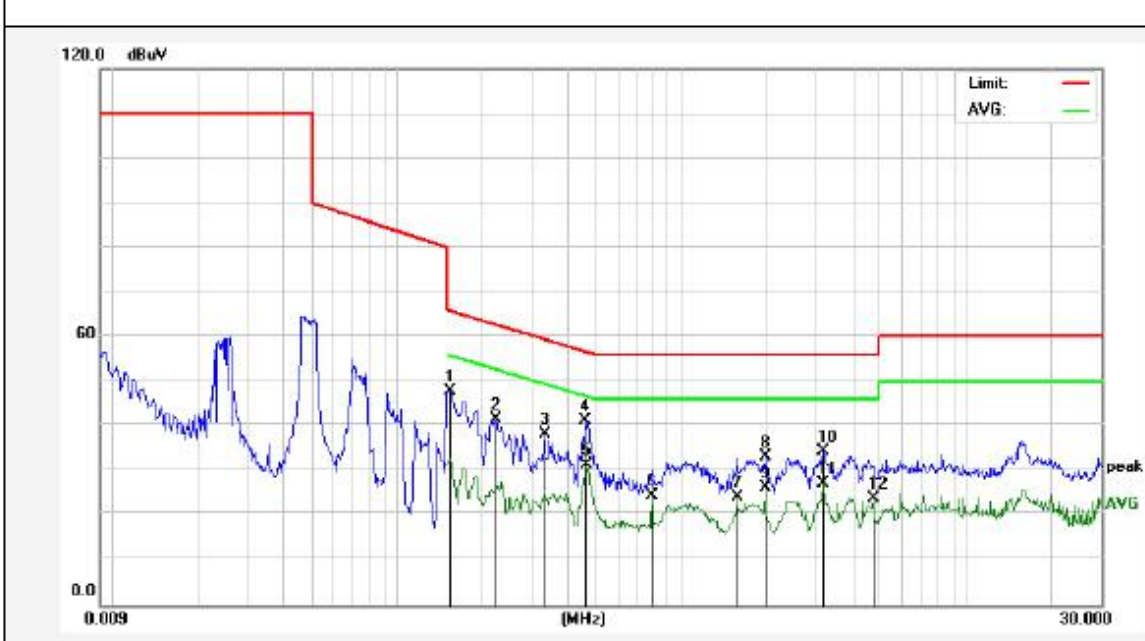

No.	Freq. (MHz)	Reading (dBuV)	Factor (dB)	Result (dBuV)	Limit dBuV	Over Limit (dB)	Detector	Remark
1	0.1539	28.01	19.90	47.91	65.78	-17.87	QP	
2	0.2220	21.72	19.90	41.62	62.74	-21.12	QP	
3	0.3300	18.37	19.90	38.27	59.45	-21.18	QP	
4	0.4620	21.35	19.96	41.31	56.66	-15.35	QP	
5	0.4660	11.36	19.96	31.32	46.58	-15.26	AVG	
6	0.7900	4.40	20.06	24.46	46.00	-21.54	AVG	
7	1.5780	4.06	20.13	24.19	46.00	-21.81	AVG	
8	1.9740	12.93	20.14	33.07	56.00	-22.93	QP	
9	1.9740	6.09	20.14	26.23	46.00	-19.77	AVG	
10	3.1580	14.08	20.16	34.24	56.00	-21.76	QP	
11	3.1580	6.87	20.16	27.03	46.00	-18.97	AVG	
12	4.7340	3.66	20.20	23.86	46.00	-22.14	AVG	

**Note:** Result=Reading+Factor Over Limit=Result-Limit

**Conducted Emission Test Data**

Test Site: 1# Shielded Room  
 Test Specification: DC 19V via adapter AC 230V, 50Hz  
 Comment: Neutral Line  
 Temp.: 22.2°C Hum.: 60%

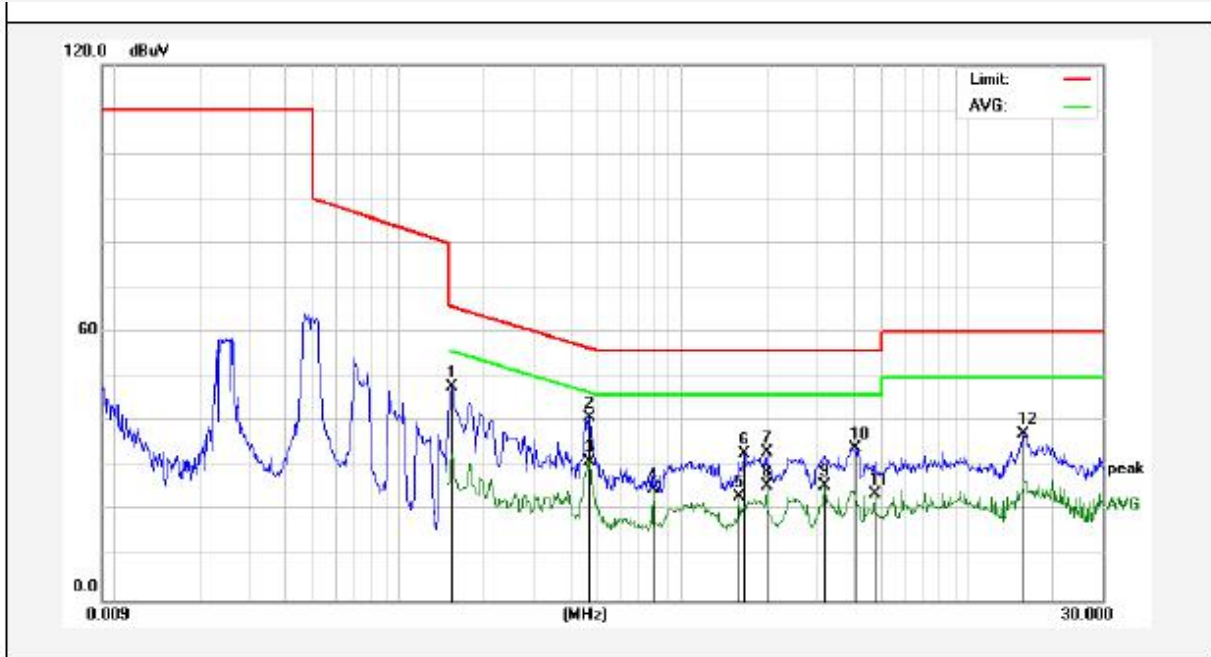

No.	Freq. (MHz)	Reading (dBuV)	Factor (dB)	Result (dBuV)	Limit dBuV	Over Limit (dB)	Detector	Remark
1	0.1539	28.04	19.90	47.94	65.78	-17.84	peak	
2	0.4700	20.98	19.97	40.95	56.51	-15.56	peak	
3	0.4700	11.17	19.97	31.14	46.51	-15.37	AVG	
4	0.7900	5.10	20.06	25.16	46.00	-20.84	AVG	
5	1.5780	3.20	20.13	23.33	46.00	-22.67	AVG	
6	1.6540	12.70	20.13	32.83	56.00	-23.17	peak	
7	1.9740	12.93	20.14	33.07	56.00	-22.93	peak	
8	1.9740	5.66	20.14	25.80	46.00	-20.20	AVG	
9	3.1540	5.47	20.16	25.63	46.00	-20.37	AVG	
10	4.0460	14.01	20.18	34.19	56.00	-21.81	peak	
11	4.7340	3.65	20.20	23.85	46.00	-22.15	AVG	
12	15.7860	17.17	20.27	37.44	60.00	-22.56	peak	

**Note:** Result=Reading+Factor Over Limit=Result-Limit

### 3. Radiated Emission Test

#### 3.1. Test Standard and Limit

Test Standard	EN 55015
---------------	----------

Radiated Emission Test Limit

Test Limit	Frequency (MHz)	DISTANCE (Meters)	FIELD STRENGTHS LIMIT (dB $\mu$ V/m)
	30 ~ 230	3	40
	230 ~ 300	3	47

**Remark:** (1) The smaller limit shall apply at the combination point between two frequency bands.  
(2) Distance refers to the distance in meters between the measuring instrument antenna and the closed point of any part of the EUT.

#### 3.2. Test Setup

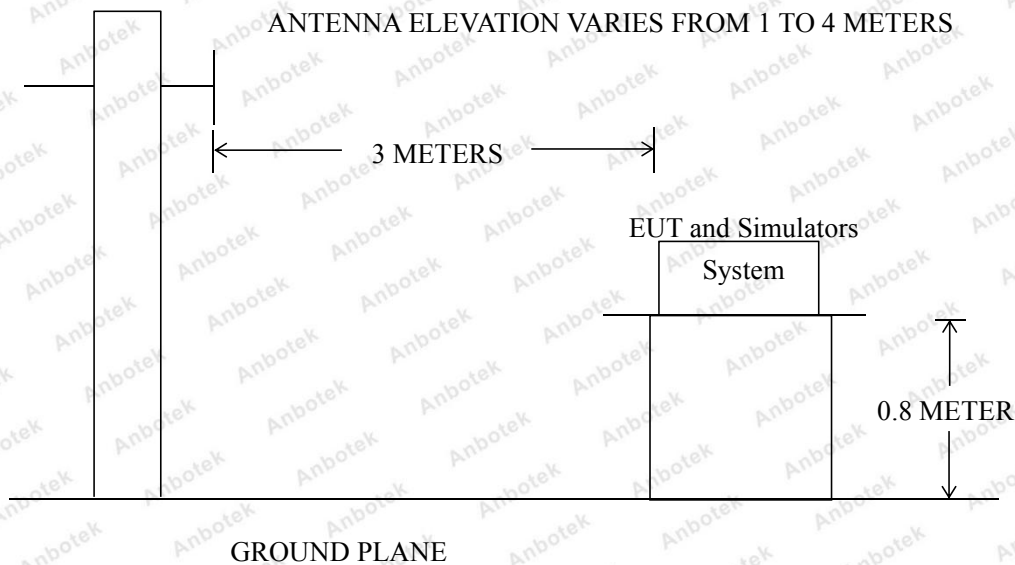

#### 3.3. EUT Configuration on Measurement

The EN 55015 regulations test method must be used to find the maximum emission during radiated emission measurement.

### 3.4. Operating Condition of EUT

- 3.4.1. Setup the EUT as shown in Section 3.2.
- 3.4.2. Turn on the power of all equipments.
- 3.4.3. Let the EUT work in test mode and measure it.

### 3.5. Test Procedure

The EUT is placed on a turn table which is 0.8 meter high above the ground. The turn table can rotate 360 degrees to determine the position of the maximum emission level. The EUT is set 3 meters away from the receiving antenna which is mounted on an antenna tower. The antenna can be moved up and down from 1 to 4 meters to find out the maximum emission level. Bilog antenna is used as a receiving antenna. Both horizontal and vertical polarization of the antenna are set on test.

The bandwidth of the Receiver (ESCI) is set at 120kHz.

The EUT is tested in Chamber.

The test results are listed in Section 3.6.

### 3.6. Test Results

**PASS**

The frequency range from 30MHz to 300MHz is investigated.

The test curves are shown in the following pages.

**Test item:** Radiation Test      **Polarization:** Horizontal  
**Standard:** (RE)EN55015      **Power Source:** DC 19V via adapter AC 230V, 50Hz  
**Distance:** 3m      **Temp.(°C)/Hum.(%RH):** 24.3( °C)/55%RH  
**Test Mode:** Charging

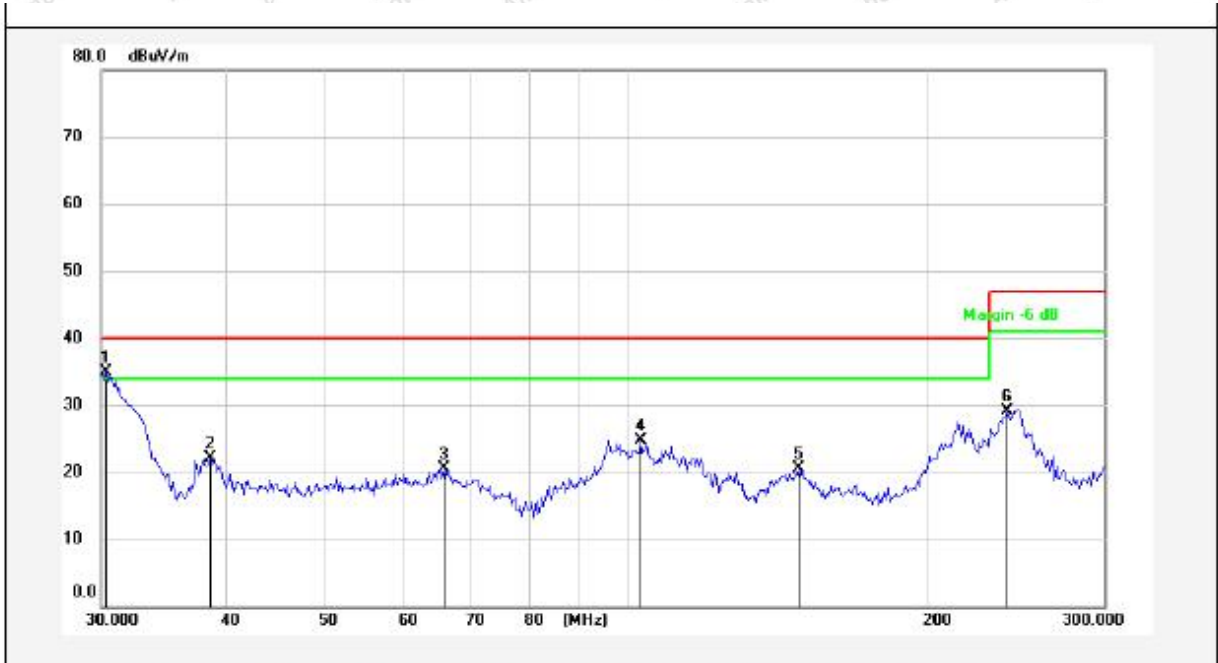

No.	Freq. (MHz)	Reading (dBuV)	Factor (dB/m)	Result (dBuV/m)	Limit (dBuV/m)	Over Limit (dB)	Detector	Height (cm)	degree (deg)	Remark
1	30.3173	50.94	-16.06	34.88	40.00	-5.12	peak			
2	38.4809	37.00	-14.94	22.06	40.00	-17.94	peak			
3	65.8031	37.97	-17.41	20.56	40.00	-19.44	peak			
4	103.4421	39.55	-14.79	24.76	40.00	-15.24	peak			
5	148.4410	39.53	-19.07	20.46	40.00	-19.54	peak			
6	239.9874	43.83	-14.76	29.07	47.00	-17.93	peak			

**Note:** Result=Reading+Factor      Over Limit=Result-Limit

**Test item:** Radiation Test      **Polarization:** Vertical  
**Standard:** (RE)EN55015      **Power Source:** DC 19V via adapter AC 230V, 50Hz  
**Distance:** 3m      **Temp.(°C)/Hum.(%RH):** 24.3( °C)/55%RH  
**Test Mode:** Charging



No.	Freq. (MHz)	Reading (dBUV)	Factor (dB/m)	Result (dBUV/m)	Limit (dBUV/m)	Over Limit (dB)	Detector	Height (cm)	degree (deg)	Remark
1	31.6195	50.38	-16.03	34.35	40.00	-5.65	QP	100	360	
2	39.0245	47.12	-14.79	32.33	40.00	-7.67	peak			
3	61.9951	44.04	-15.97	28.07	40.00	-11.93	peak			
4	103.8055	44.18	-14.83	29.35	40.00	-10.65	peak			
5	150.5378	43.89	-19.02	24.87	40.00	-15.13	peak			
6	215.2678	42.76	-15.96	26.80	40.00	-13.20	peak			

**Note:**      **Result=Reading+Factor**      **Over Limit=Result-Limit**

**Test item:** Radiation Test      **Polarization:** Horizontal  
**Standard:** (RE)EN55015      **Power Source:** DC 3.6V  
**Distance:** 3m      **Temp.(°C)/Hum.(%RH):** 24.3( °C)/55%RH  
**Test Mode:** On

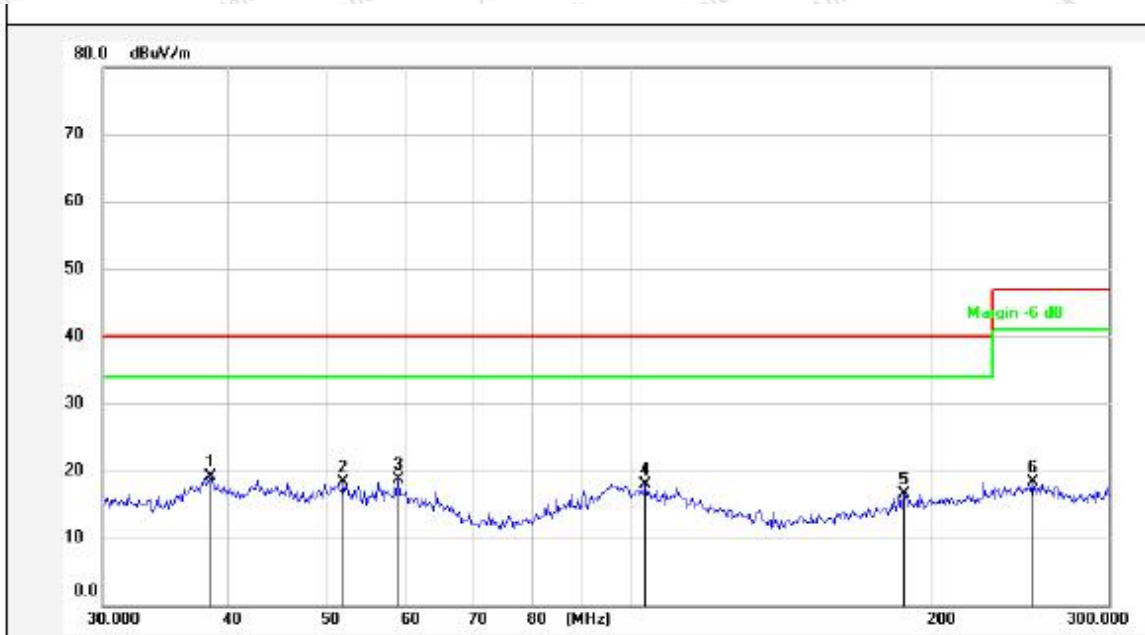

No.	Freq. (MHz)	Reading (dBuV)	Factor (dB/m)	Result (dBuV/m)	Limit (dBuV/m)	Over Limit (dB)	Detector	Height (cm)	degree (deg)	Remark
1	38.3462	34.13	-14.97	19.16	40.00	-20.84	peak			
2	52.0535	33.24	-14.90	18.34	40.00	-21.66	peak			
3	59.0251	33.86	-15.19	18.67	40.00	-21.33	peak			
4	103.8055	32.77	-14.83	17.94	40.00	-22.06	peak			
5	187.7530	33.19	-16.74	16.45	40.00	-23.55	peak			
6	252.5957	32.95	-14.73	18.22	47.00	-28.78	peak			

**Note:**      **Result=Reading+Factor**      **Over Limit=Result-Limit**

**Test item:** Radiation Test      **Polarization:** Vertical  
**Standard:** (RE)EN55015      **Power Source:** DC 3.6V  
**Distance:** 3m      **Temp.(°C)/Hum.(%RH):** 24.3(°C)/55%RH  
**Test Mode:** On

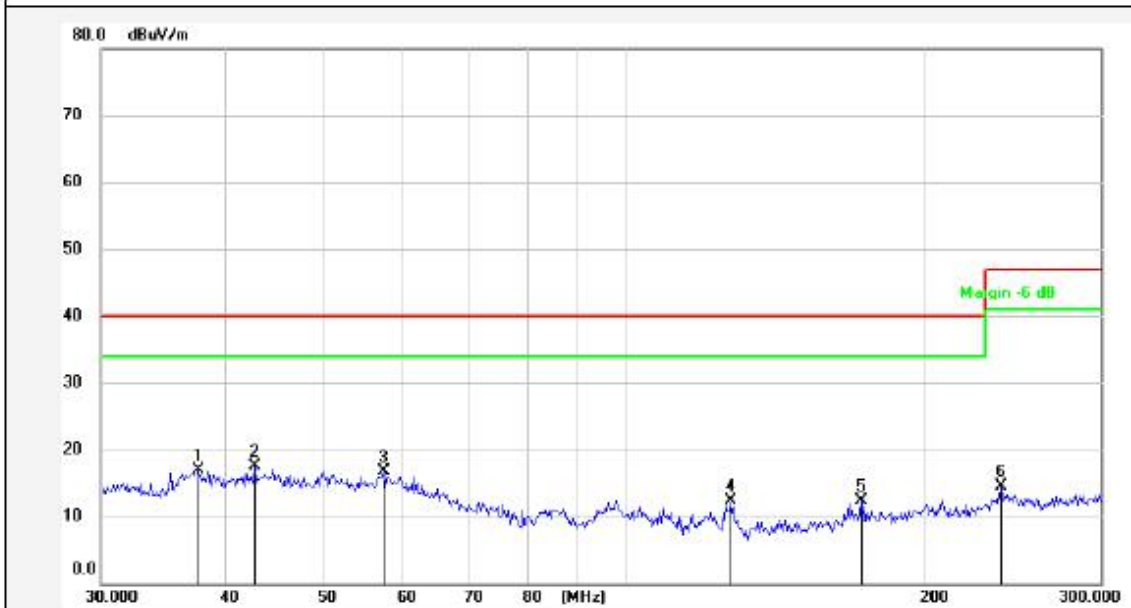

No.	Freq. (MHz)	Reading (dBuV)	Factor (dB/m)	Result (dBuV/m)	Limit (dBuV/m)	Over Limit (dB)	Detector	Height (cm)	degree (deg)	Remark
1	37.4247	32.25	-15.25	17.00	40.00	-23.00	peak			
2	42.7496	31.99	-14.55	17.44	40.00	-22.56	peak			
3	57.5939	31.79	-15.10	16.69	40.00	-23.31	peak			
4	127.8645	30.41	-18.18	12.23	40.00	-27.77	peak			
5	172.5988	30.19	-17.97	12.22	40.00	-27.78	peak			
6	238.3102	29.36	-14.86	14.50	47.00	-32.50	peak			

**Note:** Result=Reading+Factor      Over Limit=Result-Limit

## 4. Magnetic Radiated Emission Test

### 4.1. Test Standard and Limit

Test Standard	EN 55015
---------------	----------

Limits for Magnetic Radiated Emission

Test Limit	Frequency	Limits for loop diameter (dB $\mu$ A)
		2m
	9KHz ~ 70KHz	88
	70KHz ~ 150KHz	88 ~ 58*
	150KHz ~ 3.0MHz	58 ~ 22*
	3.0MHz ~ 30MHz	22

**Remark:** (1) At the transition frequency the lower limit applies.  
(2) \* decreasing linearly with logarithm of the frequency.

### 4.2. Test Setup

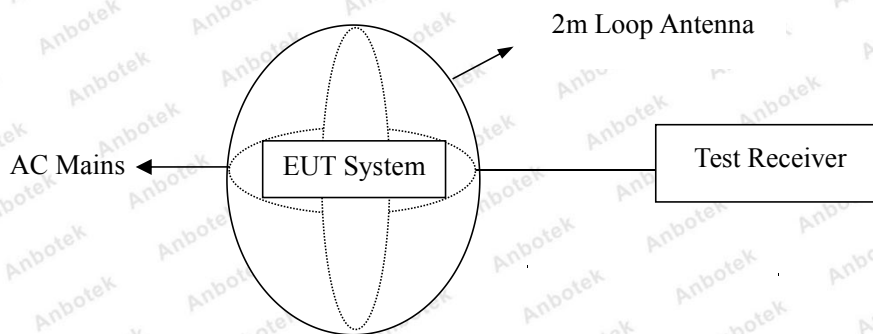

### 4.3. EUT Configuration on Measurement

The following equipments are installed on Magnetic Radiated emission Measurement to meet EN 55015 requirements and operating in a manner which tends to maximize its emission characteristics in a normal application.

### 4.4. Operating Condition of EUT

- 4.4.1. Setup the EUT as shown in Section 4.2.
- 4.4.2. Turn on the power of all equipments.
- 4.4.3. Let the EUT work in test mode and measure it.

#### 4.5. Test Procedure

The EUT is placed on a wood table in the center of a loop antenna. The induced current in the loop antenna is measured by means of a current probe and the test receiver. Three field components are checked by means of a coaxial switch.

The frequency range from 9KHz to 30MHz is investigated. The receiver is measured with the quasi-peak detector. For frequency band 9KHz to 150KHz, the bandwidth of the test receiver (ESCI) is set at 200Hz. For frequency band 150KHz to 30MHz, the bandwidth is set at 9KHz.

All the test results are listed in Section 4.6.

#### 4.6. Test Results

**PASS**

The frequency range from 9KHz to 30MHz is investigated.

The test curves are shown in the following pages.

**Magnetic Radiated Emission Test**

Test Site: 1# Shielded Room  
 Test Specification: DC 3.6V  
 Comment: X  
 Temp.: 22.2°C Hum.: 59%

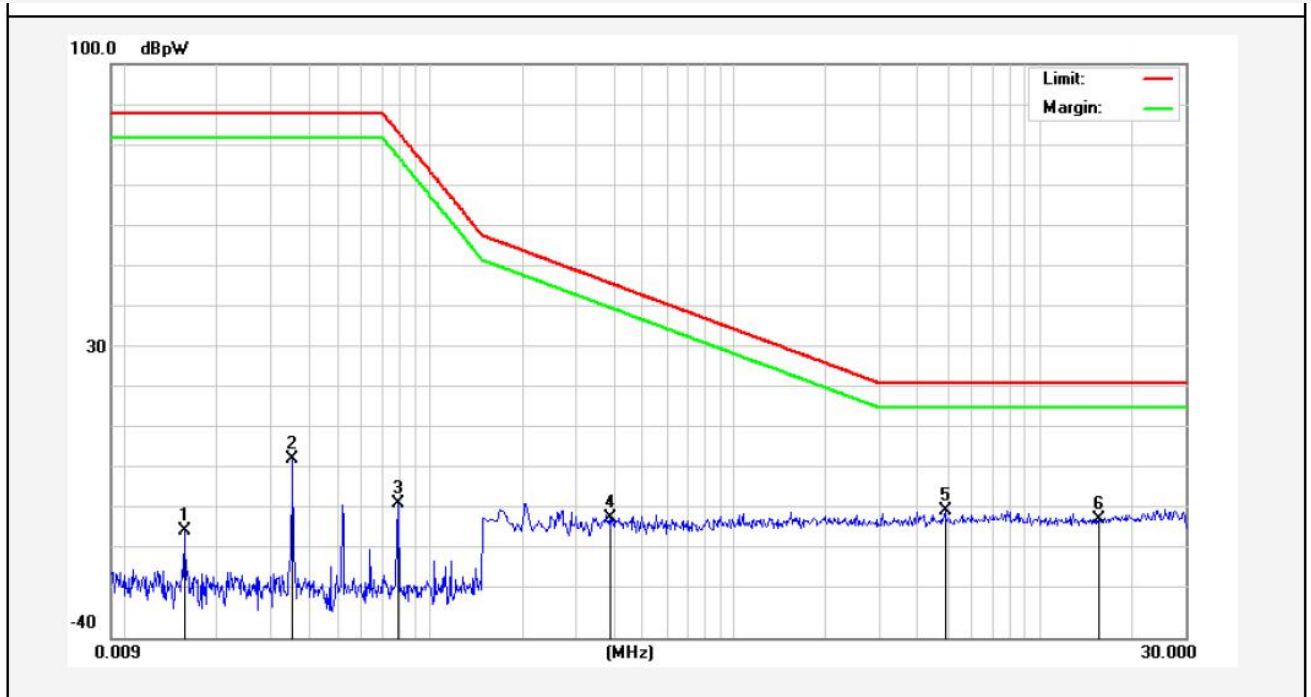

No.	Freq. (MHz)	Reading (dBpW)	Factor (dB)	Result (dBpW)	Limit dBpW	Over Limit (dB)	Detector	Remark
1	0.0155	-33.83	19.83	-14.00	88.00	-102.00	QP	
2	0.0354	-16.31	19.85	3.54	88.00	-84.46	QP	
3	0.0785	-27.19	19.95	-7.24	83.48	-90.72	QP	
4	0.3940	-30.77	19.93	-10.84	46.39	-57.23	QP	
5	4.8940	-29.18	20.20	-8.98	22.00	-30.98	QP	
6	15.6059	-31.45	20.27	-11.18	22.00	-33.18	QP	

**Note:** Result=Reading+Factor Over Limit=Result-Limit

**Magnetic Radiated Emission Test**

Test Site: 1# Shielded Room  
 Test Specification: DC 3.6V  
 Comment: Y  
 Temp.: 22.2°C Hum.: 59%

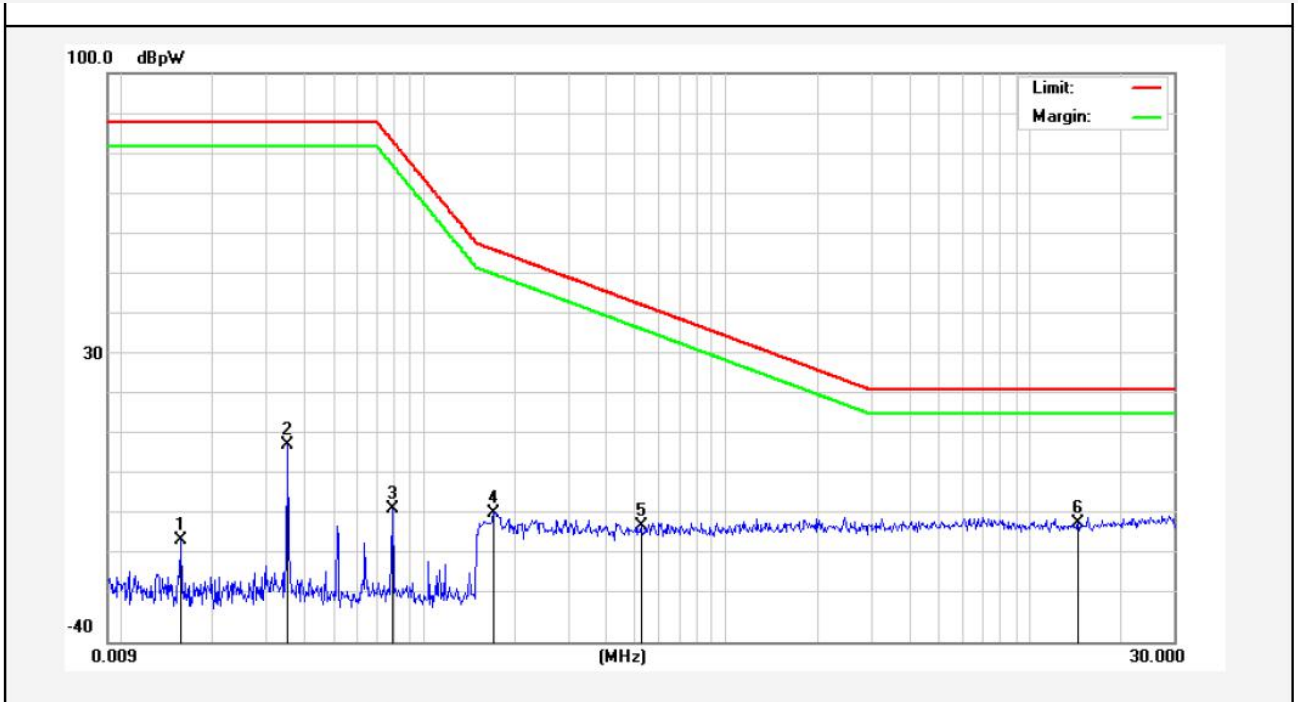

No.	Freq. (MHz)	Reading (dBpW)	Factor (dB)	Result (dBpW)	Limit dBpW	Over Limit (dB)	Detector	Remark
1	0.0158	-34.71	19.84	-14.87	88.00	-102.87	QP	
2	0.0354	-11.33	19.85	8.52	88.00	-79.48	QP	
3	0.0786	-27.25	19.95	-7.30	83.43	-90.73	QP	
4	0.1700	-28.15	19.90	-8.25	56.49	-64.74	QP	
5	0.5220	-31.48	19.99	-11.49	43.01	-54.50	QP	
6	14.4700	-31.08	20.27	-10.81	22.00	-32.81	QP	

**Note:** Result=Reading+Factor Over Limit=Result-Limit

**Magnetic Radiated Emission Test**

Test Site: 1# Shielded Room  
 Test Specification: DC 3.6V  
 Comment: Z  
 Temp.: 22.2°C Hum.: 59%

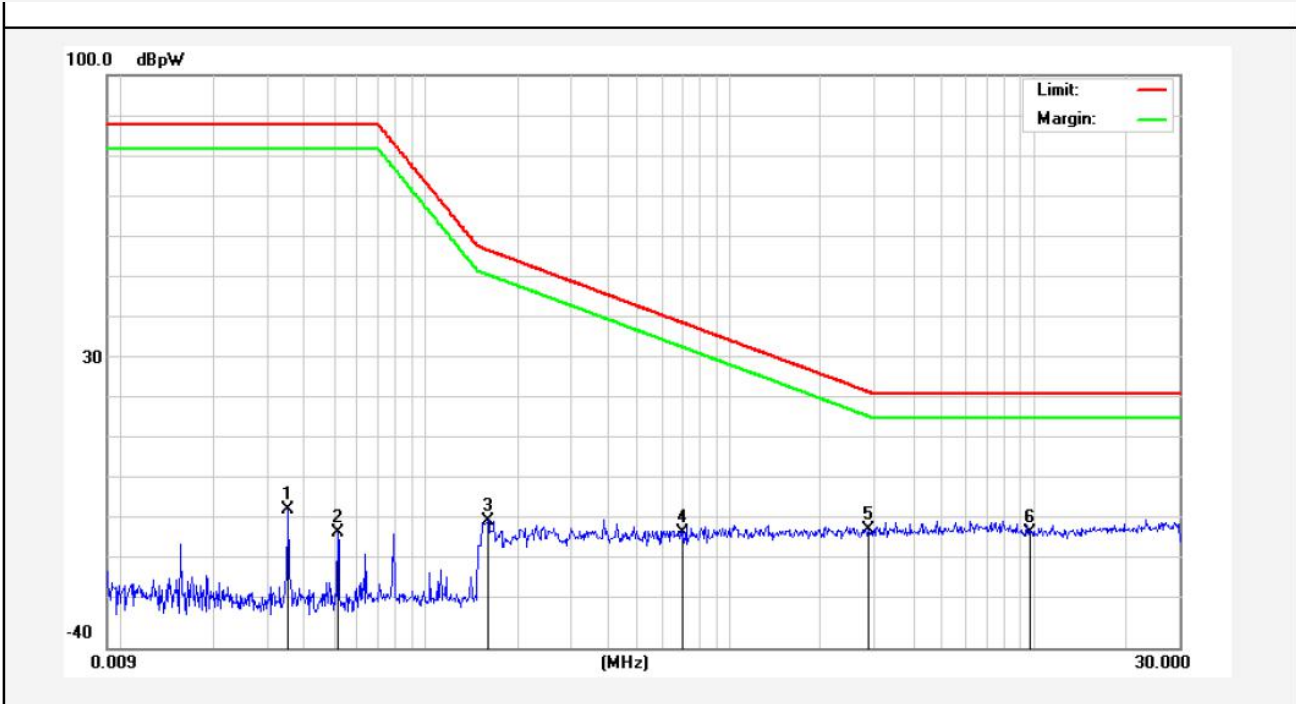

No.	Freq. (MHz)	Reading (dBpW)	Factor (dB)	Result (dBpW)	Limit dBpW	Over Limit (dB)	Detector	Remark
1	0.0354	-26.19	19.85	-6.34	88.00	-94.34	QP	
2	0.0517	-31.78	19.88	-11.90	88.00	-99.90	QP	
3	0.1602	-29.06	19.90	-9.16	57.20	-66.36	QP	
4	0.7058	-31.94	20.04	-11.90	39.39	-51.29	QP	
5	2.8699	-31.31	20.16	-11.15	22.53	-33.68	QP	
6	9.7538	-32.23	20.33	-11.90	22.00	-33.90	QP	

**Note:** Result=Reading+Factor Over Limit=Result-Limit

## 5. Harmonic Current Emission Test

### 5.1. Test Standard

Test Standard	EN 61000-3-2
---------------	--------------

### 5.2. Test Setup

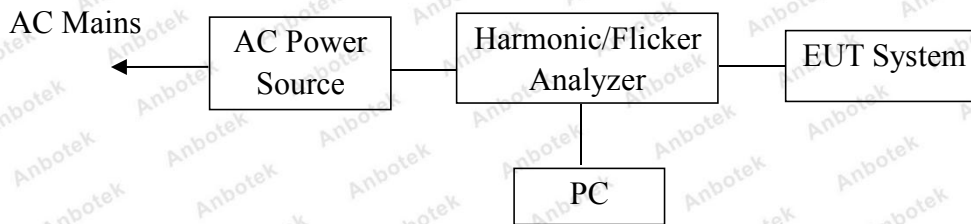

### 5.3. Operating Condition of EUT

- 5.3.1. Setup the EUT as shown on Section 5.2.
- 5.3.2. Turn on the power of all equipments.
- 5.3.3. After that, let the EUT work in test mode measure it.

### 5.4. Test Results

The active input power of the EUT is less than 25W. Therefore, according to EN 61000-3-2, no limits are necessary.

## 6. Voltage Fluctuations & Flicker Test

### 6.1. Test Standard

Test Standard	EN 61000-3-3
---------------	--------------

### 6.2. Test Setup

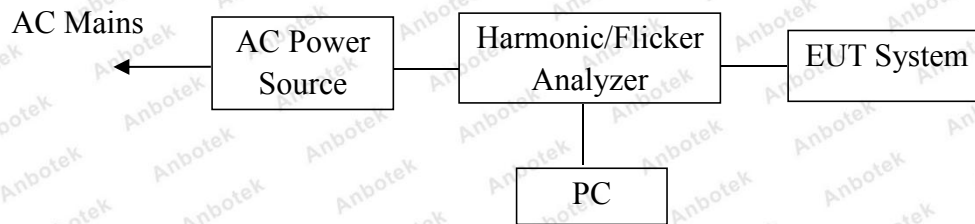

### 6.3. Operating Condition of EUT

- 6.3.1. Setup the EUT as shown on Section 6.2.
- 6.3.2. Turn on the power of all equipments.
- 6.3.3. After that, let the EUT work in test mode measure it.

### 6.4. Test Results

**PASS**

The test curves are shown in the following pages.

### Flicker Test Summary per EN/IEC61000-3-3 (Run time)

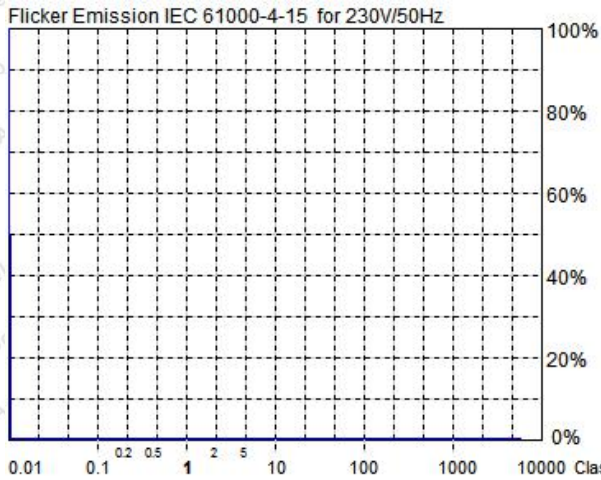

<b>Actual Flicker (Fli):</b>	<b>0.00</b>
<b>Short-term Flicker (Pst):</b>	<b>0.07</b>
Limit (Pst):	1.00
<b>Long-term Flicker (Plt):</b>	<b>0.00</b>
Limit (Plt):	0.65
<b>Maximum Relative Volt. Change (dmax):</b>	<b>0.00%</b>
Limit (dmax):	4.00%
<b>Relative Steady-state Voltage Change (dc):</b>	<b>0.00%</b>
Limit (dc):	3.00%
<b>Tmax 3.30% (dt):</b>	<b>0.00ms</b>
Limit (dt>Lim):	500ms

**Flicker Emission - IEC 61000-3-3, EN 61000-3-3**

Urms = 229.5 V P = 3.988 W  
Irms = 0.050 A pf = 0.345

Range: 0.5 A  
V-nom: 230 V

**Test aborted, Result: PASSED**

HAR-1000 EMC-Partner

**Full Bar : Actual Values**  
**Empty Bar : Maximum Values**  
**Circles : Average Values**  
**Blue : Current , Green : Voltage , Red : Failed**

Urms = 229.5V Freq = 50.000 Range: 0.5 A  
Irms = 0.050A Ipk = 0.270A cf = 5.374  
P = 3.988W S = 11.54VA pf = 0.345

**Test - Time :** 1 x 10min = 10min ( 100 %)

**LIN (Line Impedance Network) :** L: 0.24ohm +j0.15ohm N: 0.16ohm +j0.10ohm

**Limits :** Plt : 0.65 Pst : 1.00  
dmax : 4.00 % dc : 3.00 %  
dtLim: 3.30 % dt>Lim: 500ms

**Test aborted, Result: PASSED**

	dmax [%]	dc [%]	dt>Lim [ms]
<b>1</b>	<b>0.000</b>	<b>0.000</b>	<b>0.000</b>

## 7. Electrostatic Discharge Immunity Test

### 7.1. Test Standard and Level

Test Standard:	EN 61547 (IEC 61000-4-2)
Performance Criterion:	A
Severity Level: 3 / Air Discharge: $\pm 8\text{kV}$ , Level: 2 / Contact Discharge: $\pm 4\text{kV}$	

Test Level

Level	Test Voltage Contact Discharge (kV)	Test Voltage Air Discharge (kV)
1.	$\pm 2$	$\pm 2$
2.	$\pm 4$	$\pm 4$
3.	$\pm 6$	$\pm 8$
4.	$\pm 8$	$\pm 15$
X	Special	Special

### 7.2. Test Setup

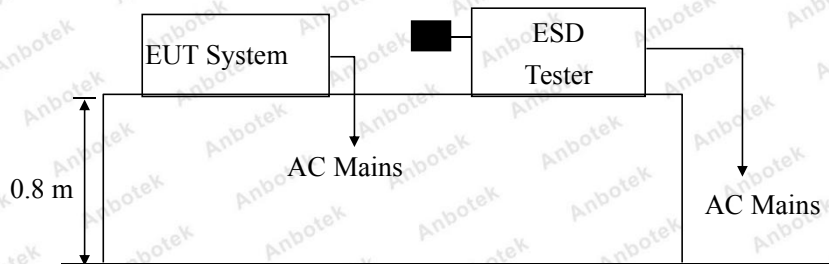

### 7.3. EUT Configuration on Measurement

The following equipments are installed on Electrostatic Discharge immunity Measurement to meet EN 61547 requirements and operating in a manner which tends to maximize its emission characteristics in a normal application.

### 7.4. Operating Condition of EUT

- 7.4.1. Setup the EUT as shown on Section 7.2.
- 7.4.2. Turn on the power of all equipments.
- 7.4.3. After that, let the EUT work in test mode measure it.

## 7.5. Test Procedure

### 7.5.1. Air Discharge:

This test is done on a non-conductive surface. The round discharge tip of the discharge electrode shall be approached as fast as possible to touch the EUT. After each discharge, the discharge electrode shall be removed from the EUT. The generator is then re-triggered for a new single discharge and repeated 10 times for each pre-selected test point. This procedure shall be repeated until all the air discharge completed.

### 7.5.2. Contact Discharge:

All the procedure shall be same as Section 7.5.1. except that the tip of the discharge electrode shall touch the EUT before the discharge switch is operated.

### 7.5.3. Indirect discharge for horizontal coupling plane

At least 20 single discharges shall be applied to the horizontal coupling plane, at points on each side of the EUT. The discharge electrode positions vertically at a distance of 0.1m from the EUT and with the discharge electrode touching the coupling plane.

### 7.5.4. Indirect discharge for vertical coupling plane

At least 20 single discharge shall be applied to the center of one vertical edge of the coupling plane. The coupling plane, of dimensions 0.5m × 0.5m, is placed parallel to, and positioned at a distance of 0.1m from the EUT. Discharges shall be applied to the coupling plane, with this plane in sufficient different positions that the four faces of the EUT are completely illuminated.

## 7.6. Test Results

**PASS**

Please refer to the following page.

## Electrostatic Discharge Test Results

Air discharge :	±8.0kV	Temperature :	24℃
Contact discharge :	±4.0kV	Humidity :	53%
Power Supply :	DC 19V via adapter AC 230V, 50Hz / DC 3.6V	Criterion required :	A
Test Result :	<input checked="" type="checkbox"/> Pass <input type="checkbox"/> Fail		
# For each point positive 10 times and negative 10 times discharge			
Location	Kind	Result	
	A-Air Discharge C-Contact Discharge		
Surface Crack	10 points	A	<input checked="" type="checkbox"/> A <input type="checkbox"/> B <input type="checkbox"/> C <input type="checkbox"/> D
Charging Port	4 points	A	<input checked="" type="checkbox"/> A <input type="checkbox"/> B <input type="checkbox"/> C <input type="checkbox"/> D
Button	4 points	A	<input checked="" type="checkbox"/> A <input type="checkbox"/> B <input type="checkbox"/> C <input type="checkbox"/> D
LED Lamp	4 points	A	<input checked="" type="checkbox"/> A <input type="checkbox"/> B <input type="checkbox"/> C <input type="checkbox"/> D
HCP	4 points	C	<input checked="" type="checkbox"/> A <input type="checkbox"/> B <input type="checkbox"/> C <input type="checkbox"/> D
VCP of the front	4 points	C	<input checked="" type="checkbox"/> A <input type="checkbox"/> B <input type="checkbox"/> C <input type="checkbox"/> D
VCP of the rear	4 points	C	<input checked="" type="checkbox"/> A <input type="checkbox"/> B <input type="checkbox"/> C <input type="checkbox"/> D
VCP of the left	4 points	C	<input checked="" type="checkbox"/> A <input type="checkbox"/> B <input type="checkbox"/> C <input type="checkbox"/> D
VCP of the right	4 points	C	<input checked="" type="checkbox"/> A <input type="checkbox"/> B <input type="checkbox"/> C <input type="checkbox"/> D
<b>Remark:</b> Discharge should be considered on Contact and Air and Horizontal Coupling Plane (HCP) and Vertical Coupling Plane (VCP).			

## 8. RF Field Strength Susceptibility Test

### 8.1. Test Standard and Level

Test Standard:	EN 61547 (IEC 61000-4-3)
Required Performance:	A
Frequency Range:	80MHz to 1000MHz
Field Strength:	3 V/m
Modulation:	1kHz Sine Wave, 80%, AM Modulation
Frequency Step:	1 % of preceding frequency value
Polarity of Antenna:	Horizontal and Vertical
Test Distance:	3 m
Antenna Height:	1.5 m
Dwell Time:	at least 3 seconds

Test Level

Level	Field Strength V/m
1.	1
2.	3
3.	10
X.	Special

### 8.2. Test Setup

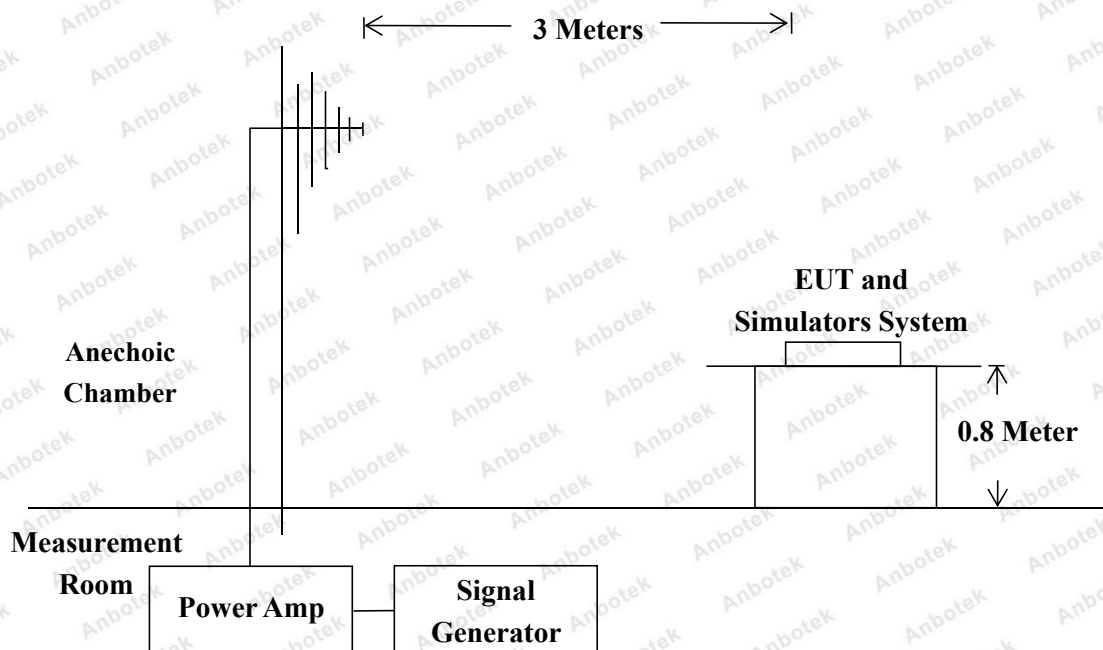

### 8.3. EUT Configuration on Measurement

The following equipments are installed on RF Field Strength susceptibility Measurement to meet EN 61547 requirements and operating in a manner which tends to maximize its emission characteristics in a normal application.

### 8.4. Operating Condition of EUT

8.4.1. Setup the EUT as shown on Section 8.2.

8.4.2. Turn on the power of all equipments.

8.4.3. After that, let the EUT work in test mode measure it.

### 8.5. Test Procedure

The EUT and support equipment, which are placed on a table that is 0.8 meter above ground and the testing was performed in a fully-anechoic chamber. The testing distance from antenna to the EUT was 3 meters.

- 1) The field strength level was 3V/m.
- 2) The frequency range is swept from 80 MHz to 1000 MHz with the signal 80% amplitude modulated with a 1kHz sine wave.
- 3) The dwell time at each frequency shall be not less than the time necessary for the EUT to be able to respond, but shall in no case be less than 0.5s.
- 4) The test was performed with the EUT exposed to both vertically and horizontally polarized fields on each of the four sides.

### 8.6. Measuring Results

**PASS**

Please refer to the following page.

## RF Field Strength Susceptibility Test Results

Field Strength :	3V/m	Temperature :	24°C
Criterion required :	A	Humidity :	53%
Power Supply :	DC 19V via adapter AC 230V, 50Hz / DC 3.6V	Test Result :	<input checked="" type="checkbox"/> Pass <input type="checkbox"/> Fail

Frequency Range (MHz)	Antenna Polarity	R.F. Field Strength	Azimuth	Result
80~1000	H / V	3 V/m (rms) AM Modulated 1000Hz, 80%	Front	<input checked="" type="checkbox"/> A <input type="checkbox"/> B <input type="checkbox"/> C <input type="checkbox"/> D
			Rear	
			Left	
			Right	

**Remark:**

This test item is subcontracted to Shenzhen EMTEK Co., Ltd.  
Bldg. 69, Majialong Industry Zone, Nanshan District, Shenzhen, Guangdong, 518052 P.R.China

**Equipment Used:**

- 1.Signal generator: Agilent;N5181A;
- 2.Power Amplifier: MILMEGA;80RF1000-175;  
MILMEGA: AS0102-55;  
MILMEGA: AS1860-50;
- 3.Log.-Per.Antenna: SCHWARZBECK: VULP 9118E;  
Broad-Band Hom Antenna: SCHWARZBECK; BBHA9120 L3F.

## 9. Electrical Fast Transient/Burst Immunity Test

### 9.1. Test Standard and Level

Test Standard:	EN 61547 (IEC 61000-4-4)
Performance criterion:	B
Severity Level 2: 1.00kV	

Test Level

Open Circuit Output Test Voltage $\pm 10\%$		
Level	On Power Supply Lines (kV)	On I/O (Input/Output) Signal data and control lines (kV)
1.	0.50	0.25
2.	1.00	0.50
3.	2.00	1.00
4.	4.00	2.00
X.	Special	Special

### 9.2. Test Setup

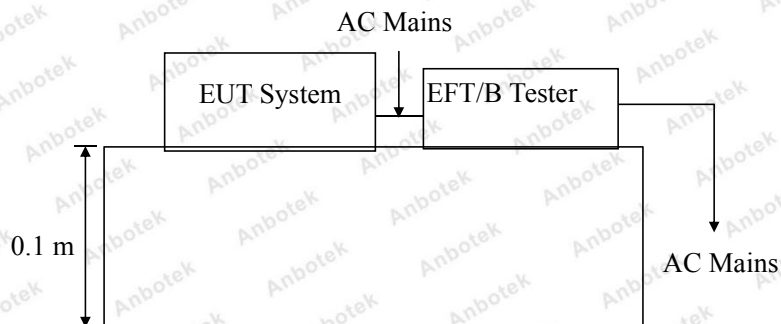

### 9.3. EUT Configuration on Measurement

The following equipments are installed on Electrical Fast Transient/Burst Immunity Measurement to meet EN 61547 requirements and operating in a manner which tends to maximize its emission characteristics in a normal application.

### 9.4. Operating Condition of EUT

9.4.1. Setup the EUT as shown in Section 9.2.

9.4.2. Turn on the power of all equipments.

9.4.3. Let the EUT work in test mode and measure it.

## 9.5. Test Procedure

The EUT is put on the table which is 0.1 meter high above the ground. This reference ground plane shall project beyond the EUT by at least 0.1m on all sides and the minimum distance between EUT and all other conductive structure, except the ground plane beneath the EUT, shall be more than 0.5m.

### 9.5.1. For input and output AC power ports:

The EUT is connected to the power mains by using a coupling device which couples the EFT interference signal to AC power lines. Both polarities of the test voltage should be applied during compliance test and the duration of the test is 2 mins.

### 9.5.2. For signal lines and control lines ports:

It's unnecessary to test.

### 9.5.3. For DC output line ports:

It's unnecessary to test.

## 9.6. Test Results

**PASS**

Please refer to the following page.

## Electrical Fast Transient/Burst Test Results

Ambient Condition : 25°C / 56% RH		Criterion required : B	
Power Supply : DC 19V via adapter AC 230V, 50Hz		Test Result : <input checked="" type="checkbox"/> Pass <input type="checkbox"/> Fail	
Inject Line : AC Mains		Inject Method: Direct	Inject Time(s): 120
Line	Polarity	Test Voltage (kV)	Result
AC Line	±	1.00kV	<input checked="" type="checkbox"/> A <input type="checkbox"/> B <input type="checkbox"/> C <input type="checkbox"/> D
DC Line			
Signal Line			

## 10. Surge Immunity Test

### 10.1. Test Standard and Level

Test Standard:	EN 61547 (IEC 61000-4-5)
Performance criterion:	B
Severity Level 1, Line to Line: 0.5kV	

Test Level

Severity Level	Open-Circuit Test Voltage (kV)
1.	0.5
2.	1.0
3.	2.0
4.	4.0
X.	Special

### 10.2. Test Setup

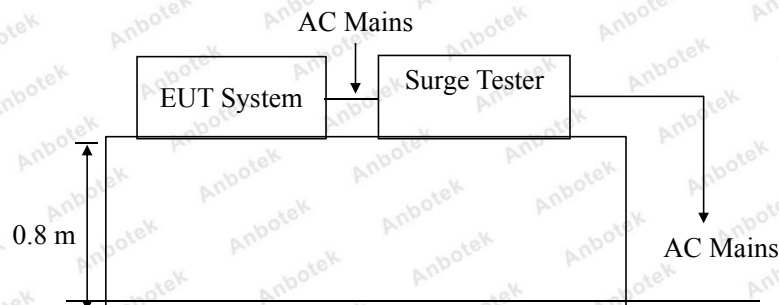

### 10.3. EUT Configuration on Measurement

The following equipments are installed on Surge immunity Measurement to meet EN 61547 requirements and operating in a manner which tends to maximize its emission characteristics in a normal application.

### 10.4. Operating Condition of EUT

10.4.1. Setup the EUT as shown in Section 10.2.

10.4.2. Turn on the power of all equipments.

10.4.3. Let the EUT work in test mode and measure it.

## 10.5. Test Procedure

10.5.1. Set up the EUT and test generator as shown on Section 10.2.

10.5.2. For line to line coupling mode, provide a 0.5 kV 1.2/50us voltage surge (at open-circuit condition) and 8/20us current surge to EUT selected points.

10.5.3. At least 5 positive and 5 negative (polarity) tests with a maximum 1/min repetition rate are conducted during test.

10.5.4. Different phase angles are done individually.

10.5.5. Record the EUT operating situation during compliance test and decide the EUT immunity criterion for above each test.

## 10.6. Test Results

**PASS**

Please refer to the following page.

## Surge Immunity Test Results

Humidity :	56%	Temperature :	25°C		
Power Supply :	DC 19V via adapter AC 230V, 50Hz	Criterion required:	B		
Test Result :	<input checked="" type="checkbox"/> Pass <input type="checkbox"/> Fail				
Location	Polarity	Phase Angle	Number of Pulse	Pulse Voltage (kV)	Result
L-N	±	<input type="checkbox"/> 0° <input checked="" type="checkbox"/> 90° <input type="checkbox"/> 180° <input checked="" type="checkbox"/> 270°	5	0.5kV	<input checked="" type="checkbox"/> A <input type="checkbox"/> B <input type="checkbox"/> C <input type="checkbox"/> D
L-PE					
N-PE					

## 11. Injected Currents Susceptibility Test

### 11.1. Test Standard and Level

Test Standard:	EN 61547 (IEC 61000-4-6)
Performance criterion:	A
Severity Level 2: 3V (rms), (0.15MHz ~80MHz)	

Test Level

Level	Field Strength V
1.	1
2.	3
3.	10
X.	Special

### 11.2. Test Setup

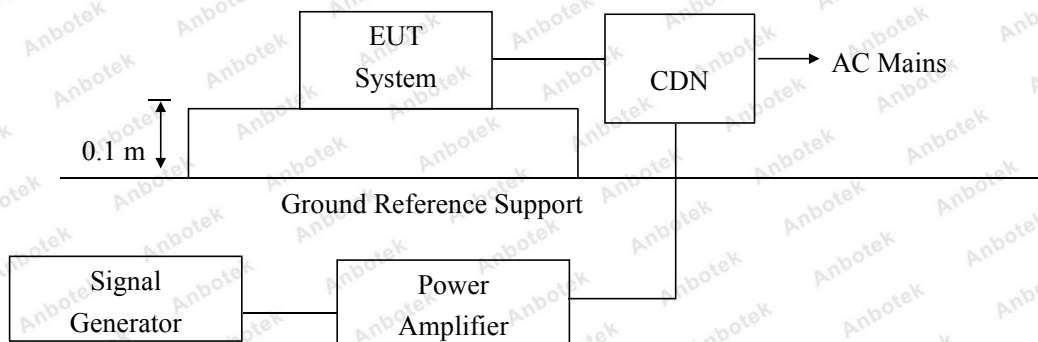

### 11.3. EUT Configuration

The following equipments are installed on currents susceptibility Measurement to meet EN 61547 requirements and operating in a manner which tends to maximize its emission characteristics in a normal application.

### 11.4. Operating Condition of EUT

11.4.1. Setup the EUT as shown in Section 11.2.

11.4.2. Turn on the power of all equipments.

11.4.3. Let the EUT work in test mode and measure it.

### 11.5. Test Procedure

- 1) Set up the EUT, CDN and test generators as shown on Section 11.2.
- 2) Let the EUT work in test mode and measure it.
- 3) The EUT are placed on an insulating support 0.1m high above a ground reference plane. CDN (coupling and decoupling device) is placed on the ground plane about 0.3m from EUT. Cables between CDN and EUT are as short as possible, and their height above the ground reference plane shall be between 30 and 50 mm (where possible).
- 4) The disturbance signal described below is injected to EUT through CDN.
- 5) The EUT operates within its operational mode(s) under intended climatic conditions after power on.
- 6) The frequency range is swept from 150KHz to 80MHz using 3V signal level, and with the disturbance signal 80% amplitude modulated with a 1KHz sine wave.
- 7) The rate of sweep shall not exceed  $1.5 \cdot 10^{-3}$  decades/s. Where the frequency is swept incrementally, the step size shall not exceed 1% of the start and thereafter 1% of the preceding frequency value.
- 8) Recording the EUT operating situation during compliance testing and decide the EUT immunity criterion.

### 11.6. Test Results

**PASS**

Please refer to the following page.

## Injected Currents Susceptibility Test Results

Humidity : 56%		Temperature : 24°C	
Power Supply : DC 19V via adapter AC 230V, 50Hz		Criterion required: A	
Test Result : <input checked="" type="checkbox"/> Pass <input type="checkbox"/> Fail			
Frequency Range (MHz)	Injected Position	Strength (Unmodulated)	Result
0.15 ~ 80	AC Mains	3V	<input checked="" type="checkbox"/> A <input type="checkbox"/> B <input type="checkbox"/> C <input type="checkbox"/> D
<b>Remark : 1. Modulation Signal:1KHz 80% AM</b>			

## 12. Voltage Dips And Interruptions Test

### 12.1. Test Standard and Level

Test Standard:	EN 61547 (IEC 61000-4-11)
Performance Criterion:	B&C

Test Level		
Test Level %UT	Voltage dip and short interruptions %UT	Duration (in period)
0	100	0.5
70	30	10 *

### 12.2. Test Setup

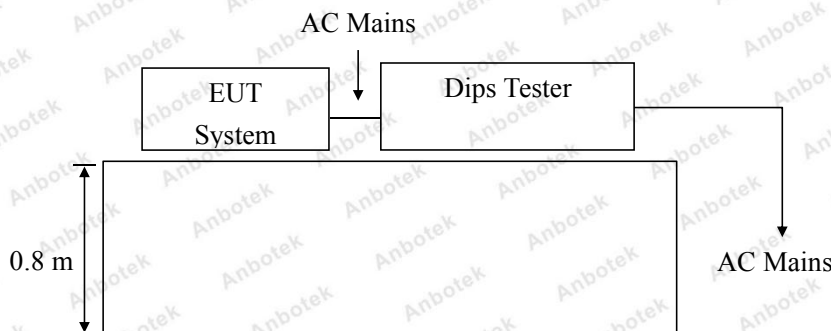

### 12.3. EUT Configuration on Measurement

The following equipments are installed on Voltage dips and interruptions Measurement to meet EN 61547 requirements and operating in a manner which tends to maximize its emission characteristics in a normal application.

### 12.4. Operating Condition of EUT

12.4.1. Setup the EUT as shown in Section 12.2.

12.4.2. Turn on the power of all equipments.

12.4.3. Let the EUT work in test mode and measure it.

## 12.5. Test Procedure

- 1) Set up the EUT and test generator as shown on Section 12.2.
- 2) The interruptions is introduced at selected phase angles with specified duration.
- 3) Record any degradation of performance.

## 12.6. Test Results

**PASS**

Please refer to the following page.

## Voltage Dips and Interruptions Test Results

Temperature : 25°C		Humidity : 56%	
Power Supply : DC 19V via adapter AC 230V, 50Hz		Criterion required : B&C	
Test Result : <input checked="" type="checkbox"/> Pass <input type="checkbox"/> Fail			
Test Level % UT	Voltage Dips & Short Interruptions % UT	Duration (in periods)	Result
0	100	0.5P	<input type="checkbox"/> A <input checked="" type="checkbox"/> B <input type="checkbox"/> C <input type="checkbox"/> D
70	30	10P	<input type="checkbox"/> A <input type="checkbox"/> B <input checked="" type="checkbox"/> C <input type="checkbox"/> D
Test Level % UT	Voltage Dips & Short Interruptions % UT	Duration (in periods)	Result

## APPENDIX I-- TEST SETUP PHOTOGRAPH

Photo of Power Line Conducted Emission Test



Photo of Radiated Emission Test (Test Mode: Charging)

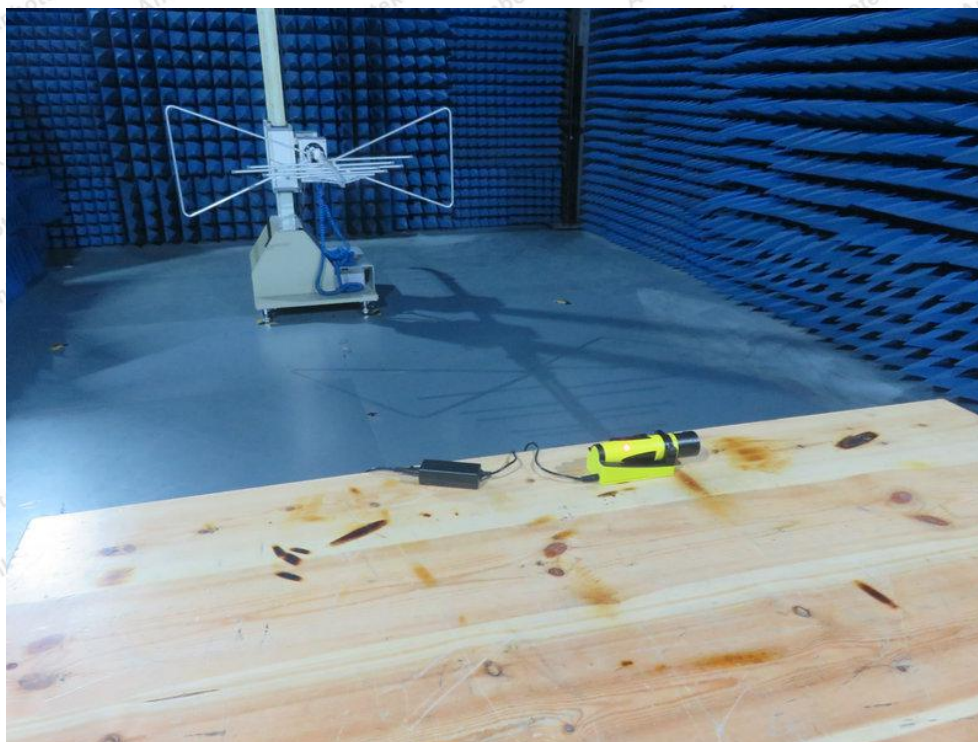

Photo of Radiated Emission Test (Test Mode: On)

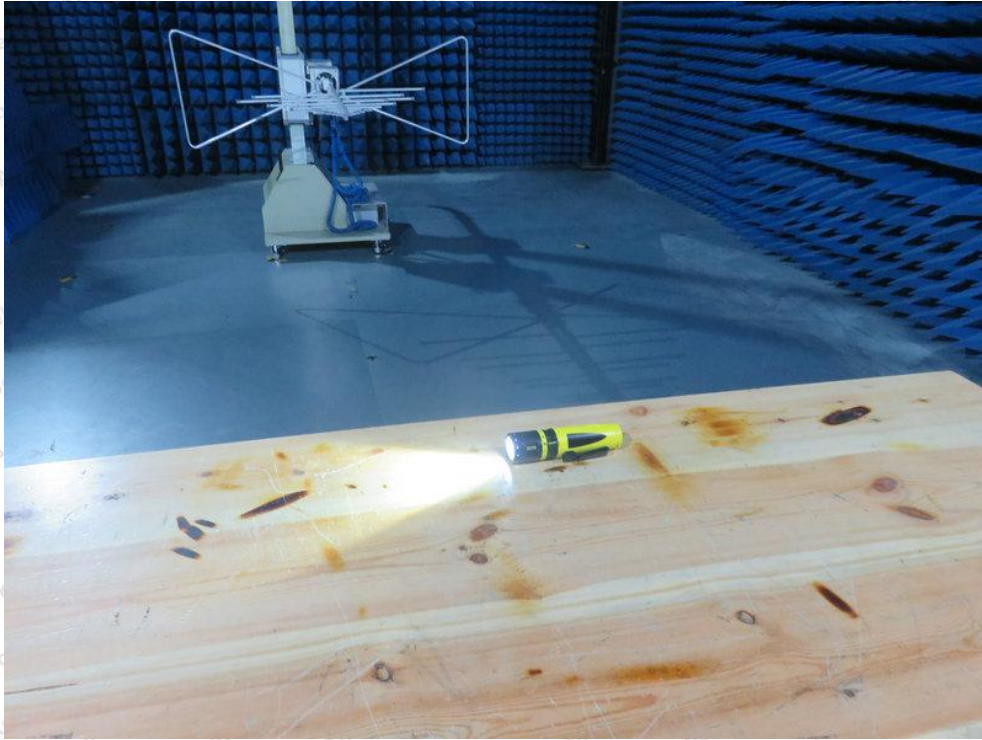

Photo of Magnetic Radiated Emission Test



Photo of Flicker/ Harmonic Test

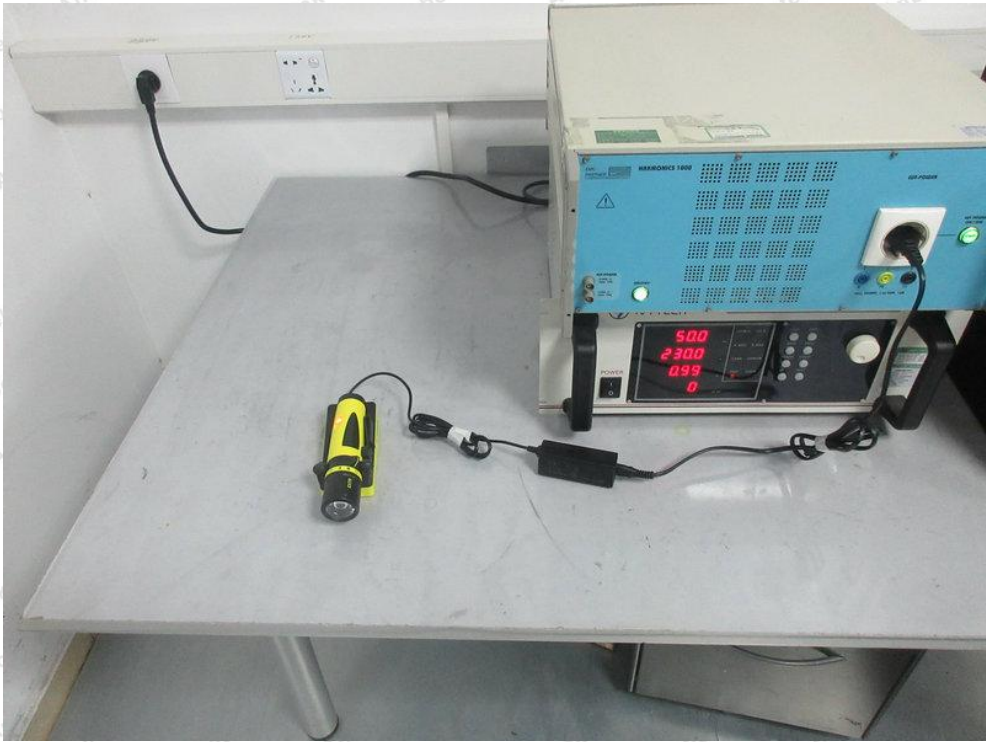

Photo of Electrostatic Discharge Immunity Test (Test Mode: Charging)





Photo of Electrostatic Discharge Immunity Test (Test Mode: On)



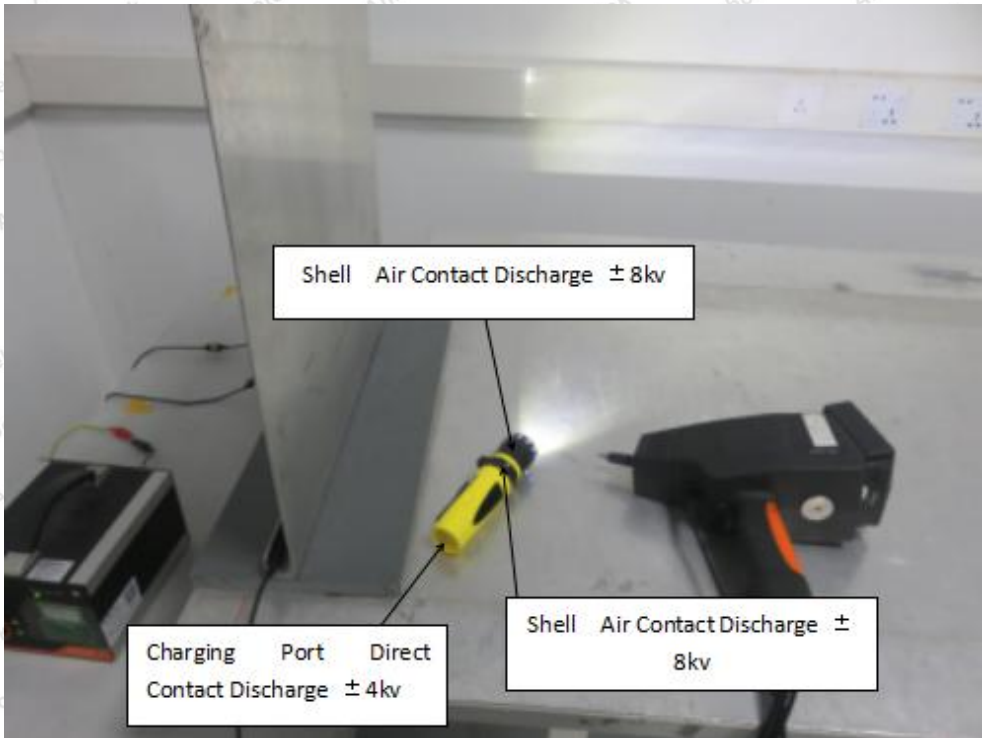

Photo of RF Field Strength susceptibility Test (Test Mode: Charging)

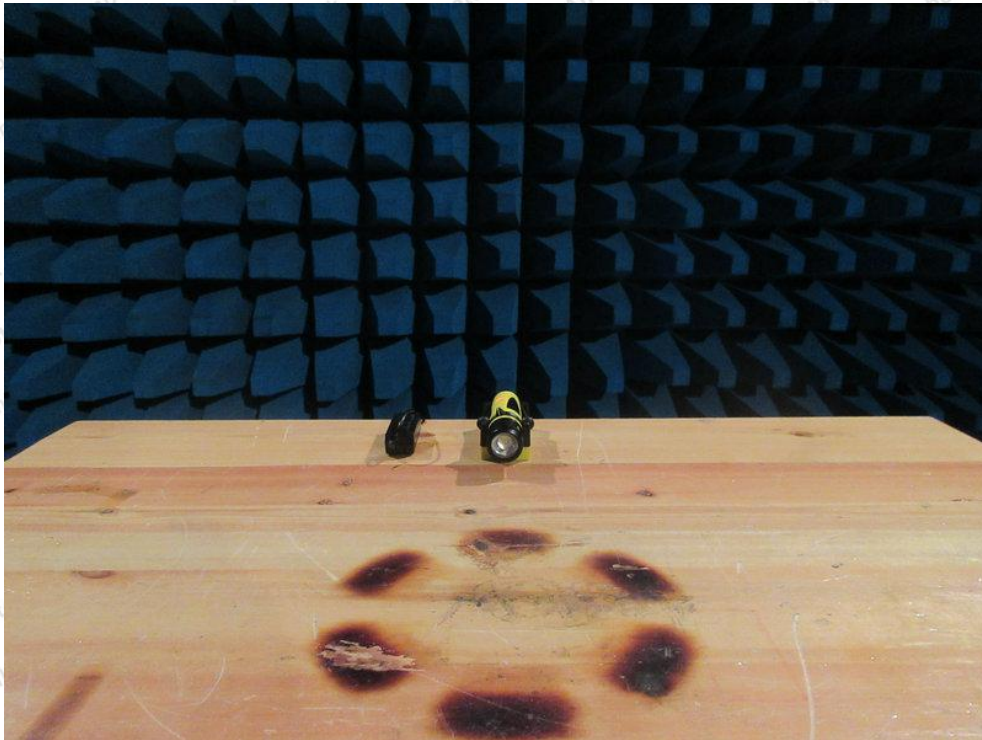

Photo of RF Field Strength susceptibility Test (Test Mode: On)

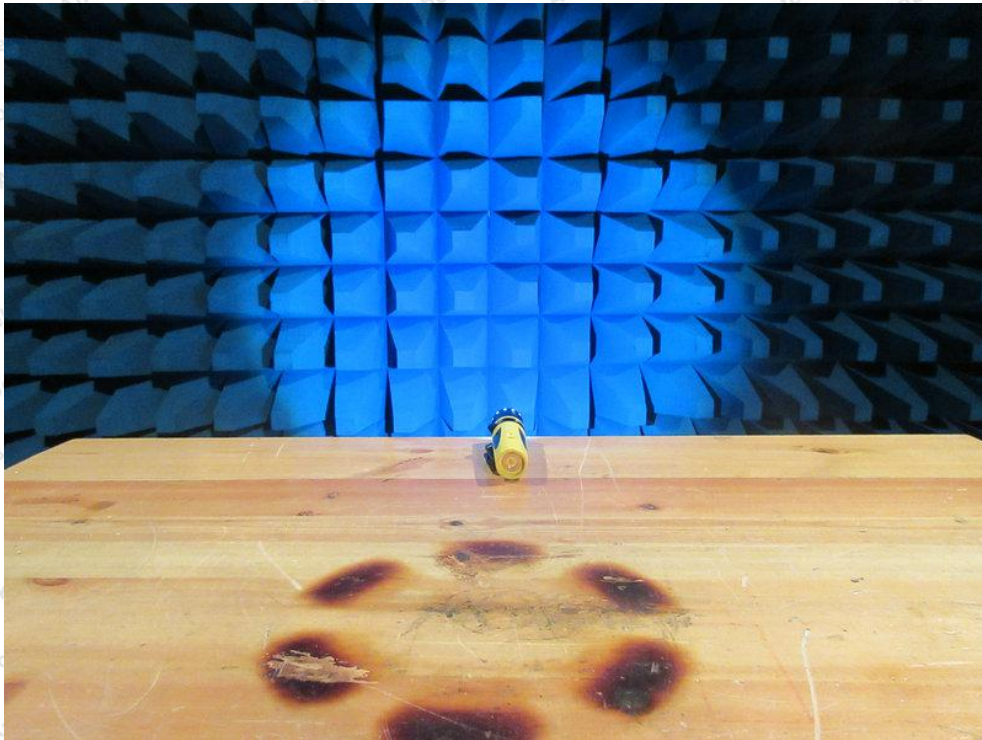

Photo of Electrical Fast Transient/Burst Immunity Test

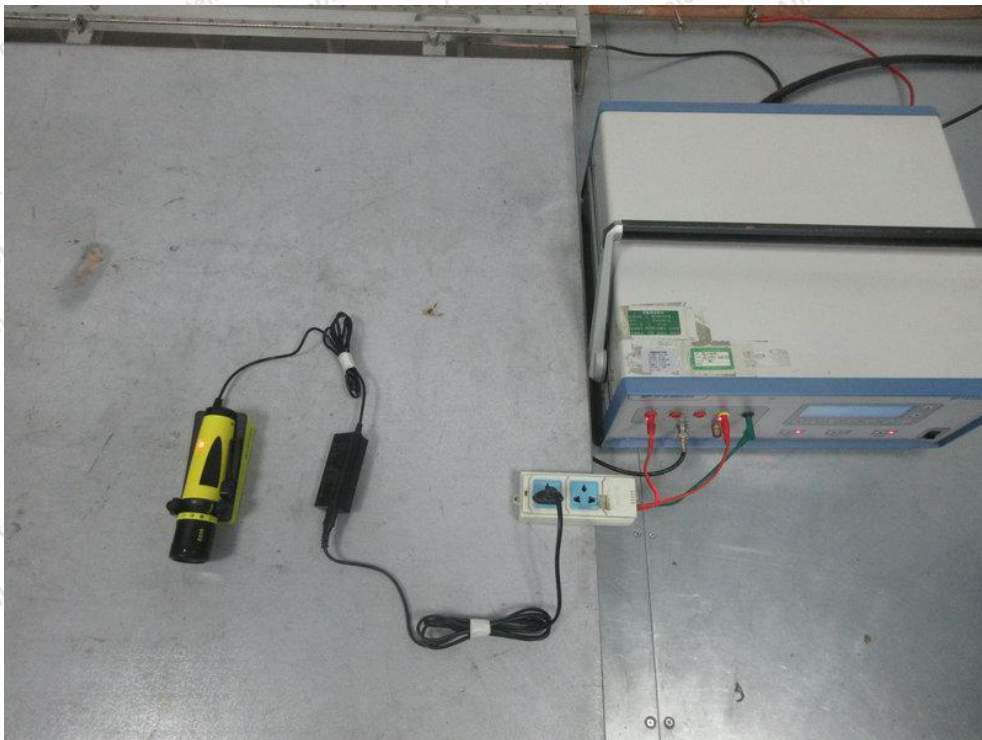

Photo of Surge Immunity Test



Photo of Injected currents susceptibility Test



Photo of Voltage Dips and Interruptions Test



## APPENDIX II -- EXTERNAL PHOTOGRAPH







## CE Label

1. The CE conformity marking must consist of the initials 'CE' taking the following form:

If the CE marking is reduced or enlarged, the proportions given in the above graduated drawing must be respected.

2. The CE marking must have a height of at least 5 mm except where this is not possible on account of the nature of the apparatus.

3. The CE marking must be affixed to the product or to its data plate. Additionally it must be affixed to the packaging, if any, and to the accompanying documents.

4. The CE marking must be affixed visibly, legibly and indelibly.

It must have the same height as the initials 'CE'.

----- End of Report -----