



Operating Manual
PremAire Combination
Self-Contained Breathing Apparatus



Order No.: 10154060/05

The Declaration of Conformity can be found under the following link: <https://MSAsafety.com/DoC>.

MSA is a registered trademark of MSA Technology, LLC in the US, Europe and other Countries. For all other trademarks visit <https://us.msasafety.com/Trademarks>.



The Safety Company

MSA Europe GmbH
Schlüsselstrasse 12
8645 Rapperswil-Jona
Switzerland

For your local MSA contacts, please go to our website www.MSAsafety.com

Contents

1	Safety Regulations	5
1.1	Correct Use	5
1.1.1	Airline devices	6
1.1.2	Escape devices	6
1.2	General Safety Regulations	7
1.3	Liability Information	8
1.4	Safety and Precautionary Measures	8
2	Description	10
2.1	Facepiece with Positive Pressure	11
2.2	Lung Governed Demand Valve	11
2.3	Automatic Switch Valve (ASV)	12
2.4	Harness Assembly	13
2.5	Combination Valve Assembly (CV)	13
2.6	Compressed Air Cylinder	14
2.7	Quick-Fill Adapter (Optional)	14
2.8	Compressed Air Supply Hose	14
2.9	Exchange Cylinder (Optional)	15
3	Approval Declaration	16
4	Use	17
4.1	Preparations for Use (shown with Mask)	17
4.2	Donning as Escape device	20
4.3	Donning as Working device	23
4.4	During Use	27
4.5	PremAire Combination Escape according to EN 402 and PremAire Combination Escape/EEBD according to EN 402, ISO 23269-1	28
4.6	PremAire Combination Airline/Escape according to EN 14593-1/EN 402 and PremAire Combination Airline/Escape/EEBD according to EN 14593-1/EN 402/ISO 23269-1	28
4.7	PremAire Combination/SCBA according to EN 14593-1/EN 137 Type 1	29
4.8	Refilling the Cylinder via MSA Quick-Fill System (if applicable)	29
4.9	After Use	30
5	Cleaning	31
5.1	Cleaning/Disinfection Facepiece	32
5.2	Lung Governed Demand Valve	32
5.3	Compressed Air Cylinder	32
6	Filling the Compressed Air Cylinder	33
6.1	Filling Connector 300 bar	33
6.2	MSA Quick-Fill System (if applicable)	34
6.3	After Filling	35
7	Sight, Function and Tightness Check	36
8	Maintenance	37
8.1	Maintenance Intervals	37
8.2	Facepiece	37
8.3	Lung Governed Demand Valve	37
8.4	Combination Valve Assembly/Compressed Air Cylinder	37
8.5	Harness Assembly	38
8.6	Quick-Fill Adapter (if Applicable)	38
8.7	Compressed Air Supply Hose	38

9	Packaging and Storage	39
	9.1 Ready to Use Storage	39
	9.2 Storage Conditions	39
10	Technical Data	40
11	Marking/Certification	41
12	Ordering Information	47

1 Safety Regulations

1.1 Correct Use

The PremAire Combination utilises a lung governed demand valve (LGDV) mounted on the facepiece. This LGDV maintains the pressure within the facepiece while regulating and reducing the air supply (air quality in accordance with EN 12021) to a breathable pressure by using a diaphragm that senses the breathing demands of the user in a controlled feedback state.

The positive pressure of air inside the facepiece, whether the wearer is inhaling or exhaling, prevents contaminants from entering the facepiece.

Device	Correct use	Norm
PremAire Combination Airline/SCBA	Airline device with SCBA device	EN 14593-1, EN 137 Type 1
PremAire Combination Airline/Escape/EEBD	Airline device with Escape device for Shipboard use	EN 14593-1, EN 402, ISO 23269-1
PremAire Combination Airline/Escape	Airline device with Escape device	EN 14593-1; EN 402
PremAire Combination Escape	Escape device	EN 402
PremAire Combination Escape/EEBD	Escape device for Shipboard use	EN 402, ISO 23269-1

The basic device consists in:

- Cylinder cover
- Compressed air cylinder
- Combination valve assembly (CV)

Parts of the basic device are also:

- Harness assembly (shoulder strap, waist belt, holster, demand valve holder)

Configurable devices:

- Facepiece
- LGDV (standard connection, Y-piece connection or T-piece connection)
- ASV

The PremAire Combination, in this manual also referred to as device, can have different configurations and approvals depending on its intended use.

The norms and standards for a device can be found on the device card in the cylinder cover.

In combination with a certified facepiece (full face mask) the device protects the wearer against inhalation of hazardous substances and mixtures, harmful biological agents and oxygen deficiency.

1.1.1 Airline devices

PremAire Combination Airline/SCBA according to EN 14593-1 with EN 137 Type 1

The Automatic Switch Valve (ASV) in combination with a compressed air supply system, a lung governed demand valve and a facepiece is a compressed airline breathing apparatus operating independently of the ambient air according to EN 14593-1. The exhalation air is released into the ambient atmosphere. The compressed airline breathing apparatus can be connected via the ASV to the self-contained breathing apparatus PremAire Combination. The combined device can now be used according to EN 14593-1, EN 137 Type 1. Only the ASV is equipped with a warning signal to indicate insufficient air supply from the airline. If the cylinder on the SCBA is completely filled, at minimum 200 l of air volume are available. In this case, the air supply is automatically switched over to the SCBA/Escape device. The device is intended for use only in industrial work situations. Without air supply system the device is also designed for working situations according to EN 137 Type 1.

PremAire Combination Airline/Escape/EEBD according to EN 14593-1 with EN 402 and ISO 23269-1

The Automatic Switch Valve (ASV) in combination with a compressed air supply system, a lung governed demand valve and a face piece is a compressed airline breathing apparatus operating independently of the ambient air according to EN 14593-1. The exhalation air is released into the ambient atmosphere. The compressed airline breathing apparatus can be connected via the ASV to the self-contained breathing apparatus PremAire Combination. The combined device can now be used according to EN 14593-1, EN 402, ISO 23269-1. The ASV is equipped with a warning signal to indicate insufficient air supply from the airline. In this case, the air supply is automatically switched over to the Escape device. The device is intended for use in industrial work situations with compressed air supply as well as in escape situation and also as Emergency Escape Breathing Device (EEBD) for shipboard use.

PremAire Combination Airline/Escape according to EN 14593-1 with EN 402

The Automatic Switch Valve (ASV) in combination with a compressed air supply system, a lung governed demand valve and a facepiece is a compressed airline breathing apparatus operating independently of the ambient air according to EN 14593-1. The exhalation air is released into the ambient atmosphere. The compressed airline breathing apparatus can be connected via the ASV to the self-contained breathing apparatus PremAire Combination. The combined device can now be used according to EN 14593-1 and EN 402. The ASV is equipped with a warning signal to indicate insufficient air supply from the airline. In this case, the air supply is automatically switched over to the Escape device. The device is intended for use in industrial work situations with compressed air supply as well as in escape situations.

1.1.2 Escape devices

WARNING!

This device is for escape only and not intended for work.

Failure to follow this warning can result in serious personal injury or death.

WARNING!

Depending on the configuration, the device may exceed the total weight of 5 kg. In this case, according to EN 402:2003, the device must not be worn on the body for more than 8 hours.

Failure to follow this warning can result in serious personal injury or death.

PremAire Combination Escape according to EN 402

The PremAire Combination in accordance with EN 402 is a positive pressure self-contained breathing apparatus (SCBA) for escape with rated service duration depending on filling pressure and cylinder size used (see table below). Breathable air is supplied to the user from a compressed air cylinder via a pressure reducer, a lung governed demand valve and a facepiece. The exhalation air is released into the ambient atmosphere. The device enables the wearer to escape from a potentially hazardous atmosphere and is equipped with a rescue airline connection for attachment to a rescue air supply in "safe havens". A warning signal is optional.

PremAire Combination Escape/EEBD according to EN 402, ISO 23269-1

The PremAire Combination in accordance with EN 402 and ISO 23269-1 is a positive pressure self-contained breathing apparatus (SCBA) for escape with rated service duration depending on filling pressure and cylinder size used (see table below). Breathable air is supplied to the user from a compressed air cylinder via a pressure reducer, a lung governed demand valve and a face piece. The exhalation air is released into the ambient atmosphere. The device enables the wearer to escape from a potentially hazardous atmosphere and is equipped with a rescue airline connection for attachment to a rescue air supply in "safe havens".

The device is also an Emergency Escape Breathing Device (EEBD) for shipboard use. A warning signal is optional.

Rated Service Duration for Escape devices according to EN 402

Cylinder size	Rated service duration based on 35 l/min breathing rate	
	Filling pressure 200 bar	Filling pressure 300 bar
1.1 l	5 min	5 min
2 l	10 min	15 min
3 l	15 min	20 min

Rated Service Duration for Escape devices according to AS/NZS 1716:2012

Cylinder size	Rated service duration based on 40 l/min breathing rate	
	Filling pressure 200 bar	Filling pressure 300 bar
2 l	5 min	10 min
3 l	10 min	15 min

1.2 General Safety Regulations

DANGER!

This device is a pure gas protection device. It is not suitable for underwater diving.

Failure to follow this warning will result in serious personal injury or death.

WARNING!

Only trained individuals should be allowed to use the device after ensuring sufficient knowledge on donning, removing and general use of the device.

Failure to follow this warning can result in serious personal injury or death.

It is imperative that this operating manual be read and observed when using the device. In particular, the safety instructions, as well as the information for the use and operation of the device, must be carefully read and observed. Furthermore, the national regulations applicable in the user's country must be taken into account for a safe use.

⚠ WARNING!

This device is supporting life and health. Inappropriate use, maintenance or servicing may affect the function of the device and thereby seriously compromise the user's life.

Before use the device operability must be verified. The device must not be used if the function test is unsuccessful, it is damaged, a competent servicing/maintenance has not been carried out, genuine MSA spare parts have not been used.

Failure to follow this warning can result in serious personal injury or death.

Alternative use, or use outside this specification will be considered as non-compliance. This also applies especially to unauthorised alterations to the device and to commissioning work that has not been carried out by MSA or authorised persons.

1.3 Liability Information

MSA accepts no liability in cases where the device has been used inappropriately or not as intended. The selection and use of the device are the exclusive responsibility of the individual operator.

Product liability claims, warranties and guarantees made by MSA with respect to the device are voided, if it is not used, serviced or maintained in accordance with the instructions in this manual.

1.4 Safety and Precautionary Measures

- Approved for use at temperatures between -30/-40 °C and +60 °C depending on facepiece certification. For detailed information, see chapter [11 Marking/Certification](#).
- The device may be used in explosive atmospheres according to the class stated in the ATEX certification. For detailed information, see chapter [11 Marking/Certification](#).
- The ATEX class of any other equipment used together with this device has to be regarded as well. The lowest class sets the limit.
- If the device is used in an explosive atmosphere, dissipative clothes and footwear must be used in conjunction with dissipative grounds.
- When used in explosive atmospheres there must be direct contact between the head harness and the head. Do not use head coverings (e.g. fire hoods) under the head harness.
- Use and storage of the mask with Kevlar (textile) harness in a vicinity that generates strong electrostatic charges in explosive atmospheres is not allowed.



Only use breathable air quality in accordance with EN 12021 or other applicable national regulations.

For Airline devices

- Approved only when the device is supplied with respirable air through an air supply hose with a minimum length of 5 m and a maximum length of 50 m within a pressure range of 6.0 to 8.5 bar.
- A maximum of 5 sections of straight or coiled air supply hose may be used in making up the working length of hose. Hose sections vary from 5 m to 50 m lengths.
- Use with adequate skin protection when worn in gases and vapours that poison by skin absorption (for example: hydrocyanic-acid gas).
- At very high breathing rates, the pressure in the facepiece during inhalation can become negative. Watch the medium pressure gauge of the air supply, and take note of the technical specifications for the lung governed demand valve.

1 Safety Regulations

- The breathable air must conform to EN 12021. Excessive levels of humidity in the breathing air at temperatures below 4 °C can cause the apparatus to malfunction (due to freezing)!
Use a water separator if necessary.
- The use of oxygen or oxygen-enriched air is not allowed.
- The oxygen content of the breathable air must be in the range 21 ±2 % by volume (dry air).
- Check that the breathable air network has sufficient capacity for all users of the device according to local legislation.
- The air supply and hose to the user(s) must be monitored by an assistant or safety officer, while watching the medium pressure gauge.
- The air supply (for example: ring line system, air supply hose) must be electrically grounded, to ensure sufficient grounding of the compressed air hoses for use in hazardous areas.
- If the air hose is not connected to the device at the user or air supply with ground contact, the grounding has to be secured in another way.
A storage or transport of uncoupled compressed air hoses at/on insulating materials is not allowed.

2 Description

The PremAire Combination utilises a lung governed demand valve (LGDV) mounted on a facepiece. The LGDV mounted on the facepiece maintains the pressure within the facepiece while regulating and reducing the air supply to a breathable pressure. This is accomplished by using a diaphragm that senses the breathing demands of the user in a controlled feedback state. The positive pressure of air inside the facepiece, whether the wearer is inhaling or exhaling, is to prevent contaminants from entering the facepiece.

The PremAire Combination is a multifunctional and configurable device.

The following figure is an overview which shows the available parts.

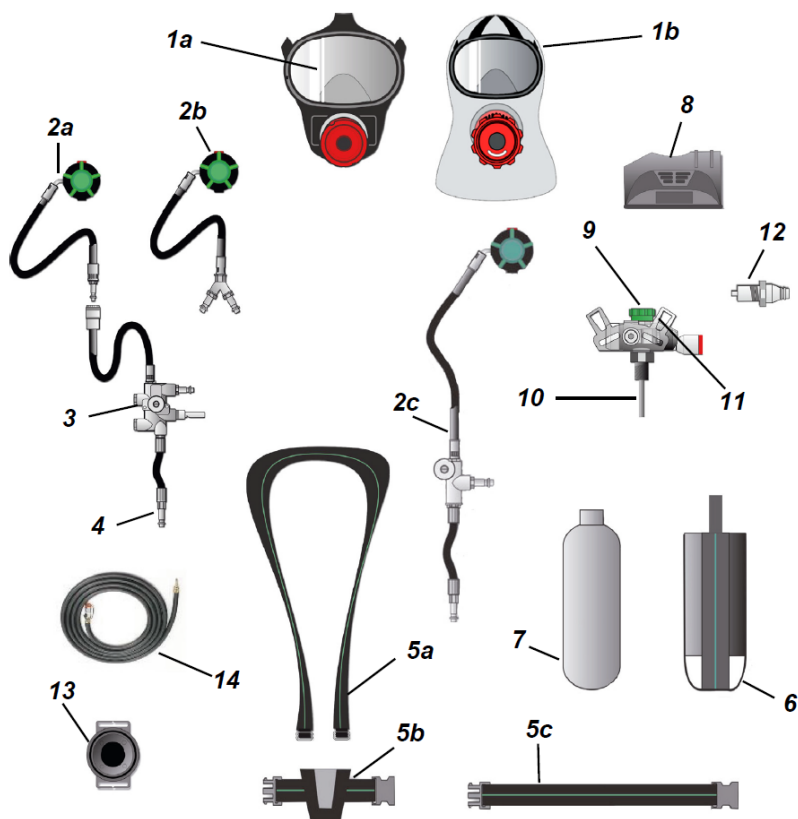

Figure 1 Overview of possible components (not true to size)

1a	Full Face Mask with Positive Pressure	6	Cylinder Cover
1b	Mask-Hood with Positive Pressure	7	Compressed Air Cylinder
2a	LGDV with standard Connection	8	Cover of Combination Valve Assembly
2b	LGDV with Y-piece Connection	9	Combination Valve Assembly (CV) (with or without warning signal)
2c	LGDV with T-piece Connection	10	Water Tube /Excess Flow Valve (EFV)
3	Automatic Switch Valve (ASV)	11	Belt Holding Plate
4	Airline Attachment Hose	12	Quick-Fill Adapter
5a	Harness Shoulder Strap	13	Demand Valve Holder

5b *Harness Holster*

14 *Compressed Air Supply Hose*

5c *Harness Waist Belt*

2.1 Facepiece with Positive Pressure

Mask with Positive Pressure

See position 1a, [Figure 1](#) .

The face blank is made of a special soft rubber compound and assures a snug, comfortable fit and a tight seal.

The inhalation air flows from the connector of the mask past the inhalation valve to the inside of the lens (thus keeping the lens largely fog-free) and then through the check valves into the nose cup. The exhalation air passes through the spring-loaded exhalation valve to the ambient air.

The mask is approved according to EN 136. The available masks are approved for use at temperatures between -30 °C / -40 °C and +60 °C depending on the mask.

For additional information see mask manual.

Mask-Hood-PS with Positive Pressure

See position 1b, [Figure 1](#) .

The PremAire Mask-Hood consists of a positive pressure full face mask (3S type) with a connection for the lung governed demand valve (LGDV) AutoMaXX AS, a hood and an easy-to-handle harness. The harness is located on the outside of the hood for better reach.

The hood covers the neck area and offers an additional seal. A tension ring inside the hood keeps the hood open when folded to ease donning.

The inhaled air flows from the connector of the mask-hood past the inhalation valve to the inside of the lens (thus keeping the lens largely fog-free) and then through the check valves into the nose cup.

The exhaled air coming out of the exhalation valve flushes the hood and then streams out of the neck opening to the ambient atmosphere. This flushing provides a slight positive pressure inside the hood.

The face blank is made of a special soft rubber compound and assures a snug, comfortable fit and a tight seal. The mask-hood is approved for use at temperatures between -40°C and +60°C.

For additional information see mask-hood manual.

2.2 Lung Governed Demand Valve

The positive pressure Lung Governed Demand Valve (LGDV) AutoMaXX AS is connected to the facepiece via a push-to-connect connection. The LGDV can be equipped with a bypass function (optional).

The LGDV is also available as ESA version, a plug-in connection according to DIN 58600:2003 for use by German fire brigade.

For additional information see LGDV manual.

WARNING!

LGDV as ESA version only works with special masks with ESA connection!

Failure to follow this warning can result in serious personal injury or death.

LGDV with Standard Connection

See position 2a, [Figure 1](#) .

The medium pressure hose of this LGDV has a standard short plug nipple to connect to the ASV, see chapter 2.3 [Automatic Switch Valve \(ASV\)](#).

LGDV with Y-piece Connection

See position 2b, [Figure 1](#).

The LGDV includes a medium pressure hose with Y-piece and two short plug nipples with non- return valves. One connection has to be connected to the ASV and the other one enables the user to connect without interruption to another air supply (or “safe havens” connector) if the original device becomes empty.

For additional information see LGDV manual.

⚠ WARNING!

This LGDV with Y-piece connection does not provide strain relief, the LGDV can therefore be pulled from the face of the wearer when connecting to rescue airline.

Failure to follow this warning can result in serious personal injury or death.

LGDV with T-piece Connection

See position 2c, [Figure 1](#).

The medium pressure hose is directly connected to the T-piece.

The T-piece consists of a brass housing and a mounting support made of stainless steel. It has two plug nipples with non-return valves. The short plug nipple is used for the SCBA connection, the long plug nipple can be used for connecting dedicated to an external rescue air supply in “safe havens”.

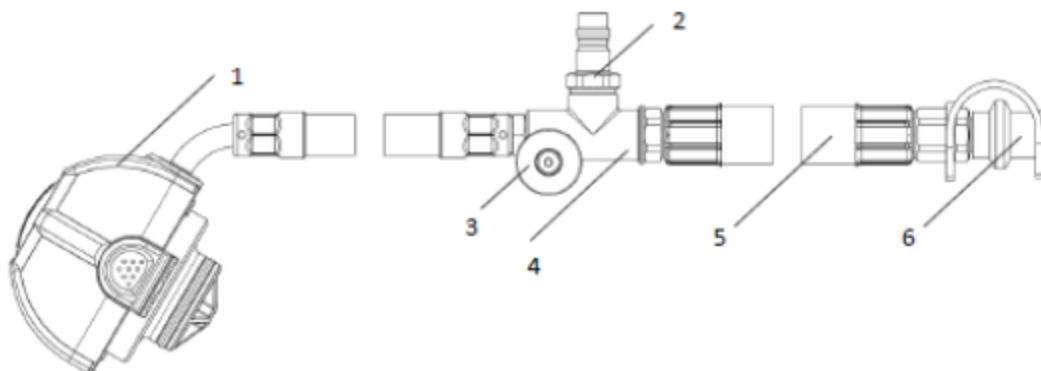

Figure 2 LGDV with T-piece connection

- 1 LGDV with medium pressure hose
- 2 Connection for SCBA (short plug nipple)
- 3 Disk (connection to the holster)
- 4 T-piece
- 5 Rescue airline attachment hose with long plug nipple
- 6 Respective dust protection cap

2.3 Automatic Switch Valve (ASV)

See position 3 and 4, [Figure 1](#).

The Automatic Switch Valve (ASV) switches automatically depending on the pressure of the supplied air between the compressed airline breathing apparatus and the SCBA/Escape device without interruption of the air supply.

2 Description

The ASV can provide air according to EN 12021 for the user from two different air sources (compressed air cylinder and e.g. ring line system).

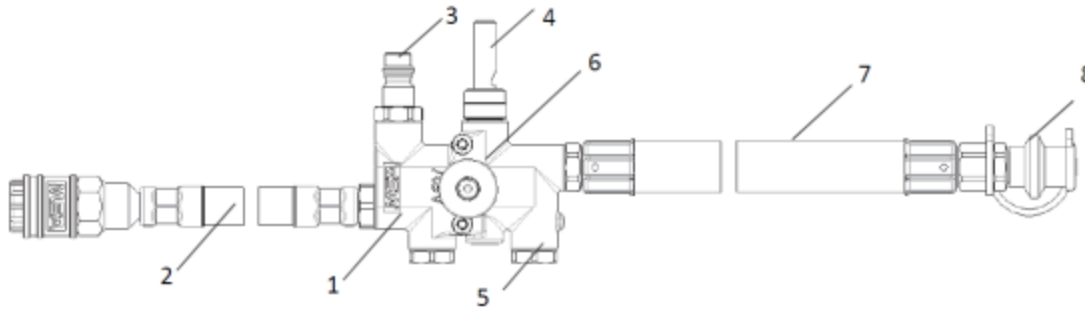

Figure 3

- 1 ASV housing
- 2 Connection for LGDV
- 3 Connection for SCBA (short plug nipple)
- 4 Warning signal
- 5 Additional connection for e.g. a tool operated by compressed air
- 6 Disk (connection to the holster)
- 7 Airline attachment hose with long plug nipple
- 8 Respective dust protection cap

2.4 Harness Assembly

See position 5a, 5b and 5c, [Figure 1](#) .

The harness assembly consists of a waist belt, a holster and a shoulder strap. The waist belt includes adjustment buckles and a holster for connecting the combination valve assembly or the ASV. The shoulder strap also includes adjustment buckles.

2.5 Combination Valve Assembly (CV)

See position 8 and 9, [Figure 1](#) .

The combination valve assembly includes a high pressure cylinder valve and first stage pressure reducer valve, all combined in the valve housing and protected by a valve cover.

The combination valve assembly consists of:

- handwheel of the cylinder valve to open and close cylinder air supply
- recessed/protected pressure gauge to permanently indicate the filling status of the cylinder by showing the air pressure
- filling connector 300 bar G 5/8" according to EN 144-2 with non-return valve to pressurise the cylinder
- high pressure burst cap to protect cylinder from over-pressurisation
- medium pressure relief valve to protect LGDV from over-pressurisation
- first stage pressure reducer valve to reduce cylinder pressure to a suitable medium pressure
- water tube or excess flow valve
- cylinder connector according to EN 144-1
- warning signal (optional/ not available for the device combination PremAire Combination Airline/SCBA according to EN 14593-1 with EN 137 Type 1)

2.6 Compressed Air Cylinder

See position 7, [Figure 1](#) .

The compressed air cylinders are applied as breathing air cylinders with a service pressure of 200 bar and 300 bar, respectively.

The compressed air cylinders are qualified for filling with breathing air according to EN 12021.

The compressed air cylinders are manufactured and CE-marked in accordance with the requirements of the Pressure Equipment Directive 2014/68/EU. The assembly group (compressed air cylinder and cylinder valve) is controlled according to the conformity assessment procedure of Module H (full quality assurance) of Directive 2014/68/EU by the notified body: DEKRA (Reg-No 2266), Handwerksstr. 15, 70565 Stuttgart.

The certified compressed air cylinders are listed in the EC-Declaration of Conformity.

All combination valve assemblies are fitted with a water tube or with an excess flow valve. The excess flow valve delivers a restricted amount of compressed air in case of a fracture of the cylinder connector to safely prevent the dangerous rebound.

2.7 Quick-Fill Adapter (Optional)

See position 12, [Figure 1](#) .

The Quick-Fill Adapter is screwed into the cylinder filling port. For permanent attachment a fastening torque of 10 Nm is recommended. It is accessible after removing the protection cap. The Quick-Fill System permits a quick refilling of the compressed air cylinder, while the SCBA may still be in use. Due to the non-return valve it is not possible to provide air. Only receiving air is intended!

WARNING!

Do not grease the Quick-Fill couplings. Contact with oil, grease and other chemicals must be avoided.

Failure to follow this warning can result in serious personal injury or death.

WARNING!

If, during filling, a leak occurs, filling must be stopped.

Failure to follow this warning can result in serious personal injury or death.

2.8 Compressed Air Supply Hose

See position 14, [Figure 1](#) .

The compressed air line breathing apparatus is available in the standard lengths of 5, 10, 20, 30 and 50 m. The hoses are fitted with a one-hand safety coupling and can be connected to each other.

Total length should be no more than 50 m. Compressed air supply hoses may be connected to each other. The couplings can also be connected while under pressure.

Maximum number of compressed air supply hoses: 5

The permitted working pressure in the compressed air supply hoses is 6.0 to 8.5 bar.

The compressed air supply hoses are:

- flexible
- extremely crush-resistant and kink-resistant,
- heat-resistant (identified by the letter "H"),
- flame-resistant (identified by the letter "F"),

- antistatic (identified by the letter “S”),

and they can therefore withstand the high stresses to which they may be subjected in industry and mining.

2.9 Exchange Cylinder (Optional)

Contact MSA at www.MSAafety.com for information.

3 Approval Declaration

PremAire Combination Device according to EN 137:2006 Type 1

Only PremAire Combination devices with 2 l or 3 l cylinder are available with approval according to EN 137:2006 Type 1. In combination according to EN 14593-1, the devices have no warning signal on the SCBA. The warning signal is located exclusively on the automatic switch valve (ASV). Devices according to EN 137:2006 Type 1 can also be combined with devices according to EN 14593-1:2005.

PremAire Combination Device according to EN 14593-1

Only PremAire Combination devices with ASV are available with approval according to EN 14593-1. ASVs marked with EN 14593-1 can either be combined with PremAire Combination devices according to EN 137:2006 Type 1 or with devices according to EN 402 and/or ISO 23269-1.

PremAire Combination Device according to EN 402

Every possible PremAire Combination configuration is available with approval according to EN 402, except for devices with approval according to EN 137.

PremAire Combination Device according to ISO 23269-1

Every PremAire Combination configuration excluding the 1,1 l cylinder is available with approval according to ISO 23269-1, except for devices with approval according to EN 137.

4 Use

⚠ WARNING!

- Only trained individuals should be allowed to use the device after ensuring sufficient knowledge on donning and general use of the device.
- Only use PremAire Combination according to EN 137 Type 1 or EN 14593-1 for working assignments! Never use devices only approved to EN 402 and ISO 23269-1 for working assignments! These devices are designed for escape purposes only. Follow company safety guidelines to implement escape procedures.
- The device may only be put into use in a fully maintained and tested condition. If malfunctions or defects are noticed prior to use, do not use the device under any circumstances. Get the device checked and repaired by an MSA authorised service centre.
- When disconnecting the compressed air hose ends while they are under pressure the plug nipple side must be held firmly. The escaping air could otherwise cause the hose to be propelled in an uncontrolled way (especially long hoses).
- Take care not to damage the device during carrying and donning.

Failure to follow these warnings will result in serious personal injury or death.

Handling the Coupling

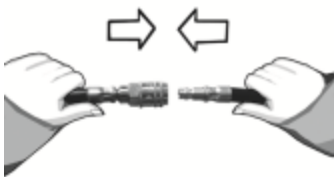

To connect:

- Push plug nipple into coupling until coupling sleeve engages.

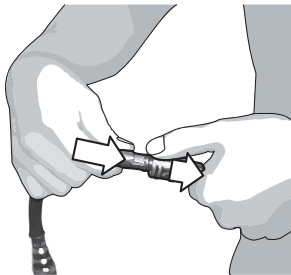

To disconnect:

- Push plug nipple into coupling and at the same time pull back coupling sleeve. Plug nipple can now be pulled out.

4.1 Preparations for Use (shown with Mask)

1. Before use, check the pressure gauge to ensure a fully pressurised cylinder.

At room temperature the pressure value has to be minimum 200/300 bar.

2. Check that the device is undamaged.

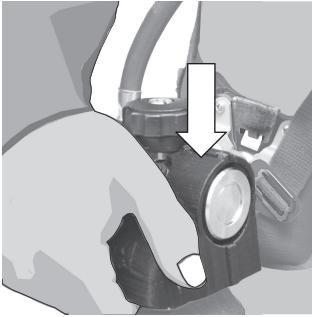

3. Connect the combination valve assembly to the harness assembly by sliding the disc into the slot of the holster.



4. Attach airline attachment hose to cylinder cover.



5. Connect SCBA connection of T-piece or ASV (not shown) to coupling of combination valve assembly.

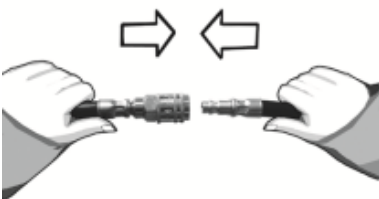

6. Connect LGDV via plug nipple to the coupling of the ASV (only ASV configurations, not for T-piece).



7. If the device is used for escape only: Connect LGDV to the facepiece.
8. Switch off the positive pressure function of the LGDV with the operation button.

9. Fully extend the shoulder strap and waist belt.

Preparing the Quick-Fill Adapter (if applicable)

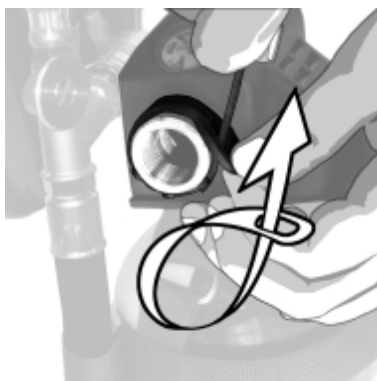

1. Screw off connector protection cap.

2. Install Quick-Fill protection cap.



3. Screw in Quick-Fill adapter.

For permanent attachment a fastening torque of 10 Nm is recommended.



4. Close with Quick-Fill protection cap.

⚠ CAUTION!

Quick-Fill has always to be covered after use with the Quick-Fill protection cap.

Failure to follow this caution can result in minor or moderate injury.

4.2 Donning as Escape device

⚠ WARNING!

To ensure safe and fast donning in an emergency, users have to train the donning procedure sufficiently.

Failure to follow this warning can result in serious personal injury or death.



1. Grab shoulder strap.
2. Check correct orientation of shoulder strap.

The MSA label must not be upside down.

Holster inside must be on the body side.

In the dark, check by touch.



3. Don shoulder strap.

4. Completely open cylinder valve with the handwheel and check the pressure gauge to ensure a fully pressurised cylinder.
5. Listen and inspect for air leakage from the LGDV, cylinder valve assembly and hose connections.

Don mask:



6. Spread the head harness with both hands.
7. Position the chin into the chin cup.
8. Pull the head straps over your head.

Whilst doing so, ensure that the harness is sitting correctly and is not twisted.



9. If necessary adjust mask and tighten the straps in order as shown firmly and evenly.

When tightening the head straps ensure that the correct sequence is followed (Figure pos. 1 - 3).

Masks with IH-harness just have to be tighten to pos. 1.

⚠ WARNING!

Ensure that the top of the mask seal only lies on the user's forehead. Hair should not be between the mask's seal and the user's skin.

The mask could otherwise leak. This danger also exists for instance for mask wearers with beards or deep scars in the sealing area.

Failure to follow this warning can result in serious personal injury or death.

⚠ WARNING!

In order to guarantee a proper fit for those wearing glasses, the mask specific spectacle kit must be worn since ordinary glasses cannot be worn under the mask.

Failure to follow this warning can result in serious personal injury or death.



Alternatively, don mask-hood:

10. To ensure quick donning, slip the mask-hood over the face from back of the head.



11. Make sure that chin and nose are properly covered by the facepiece.



12. Pull firmly on the head straps backwards on both sides to tighten as shown.

13. Pull firmly on the neck string until a tight fit at the neck is achieved.



14. Secure neck string with the stopper.

This ensures an additional neck seal of the hood.

During use head straps and neck string can be readjusted to ensure a consistent proper fit of the mask-hood.

15. To activate the LGDV, inhale once forcefully or push flush button.

16. Check positive pressure by inserting a finger into mask seal and listen for outward leak.

17. Allow mask to reseal. Then hold your breath while listening carefully for leaks. If leaks are detected reposition mask and adjust harness.



18. Don waist belt and close buckle.



19. Slide arm through shoulder strap to move cylinder to the desired side.

The position can be changed during use.



20. Adjust harness so that the device fits comfortably.



Device is ready for use.

4.3 Donning as Working device



1. Grab shoulder strap.
2. Check correct orientation of shoulder strap.

The MSA label must not be upside down.

Holster inside must be on the body side.

In the dark, check by touch.



3. Don shoulder strap.
4. Don waist belt and close buckle.
5. Slide arm through shoulder strap to move cylinder to the desired side.

The position can be changed during use.

6. Adjust harness so that the device fits comfortably.

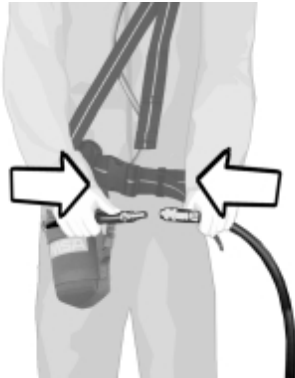

7. Open the airline supply and check the operating (medium) pressure (6.0 - 8.5 bar).
8. Connect the compressed air supply hose (this can be coupled/uncoupled even under pressure) with ASV.

⚠ WARNING!

Pressurised hose. Especially with longer lengths of hose, hold the plug nipple side firmly, otherwise escaping air can cause the hose to beat!

Failure to follow this warning can result in serious personal injury or death.



9. Completely open cylinder valve with the handwheel and check the pressure gauge to ensure a fully pressurised cylinder.
10. Listen and inspect for air leakage from the LGDV, cylinder and valve assembly, and hose connections.
11. Don mask.

When not in use, the mask is carried using the harness in front of the chest. In order to protect the inside of the mask from dirt, the harness hook is engaged in the front buckle when the mask is held in front of the chest.



- 12. Spread the head harness with both hands.
- 13. Position the chin into the chin cup.
- 14. Pull the head straps over your head.

Whilst doing so, ensure that the harness is sitting correctly and is not twisted.

- 15. If necessary adjust mask and tighten the straps in order as shown firmly and evenly.

When tightening the head straps ensure that the correct sequence is followed (Figure pos. 1 - 3). Masks with IH-harness just have to be tightened to pos. 1.



Alternatively, don mask-hood:

- 16. To ensure quick donning, slip the mask-hood over the face from back of the head.



- 17. Make sure that chin and nose are properly covered by the facepiece.



- 18. Pull firmly on the head straps backwards on both sides to tighten as shown.
- 19. Pull firmly on the neck string until a tight fit at the neck is achieved.



20. Secure neck string with the stopper.

This ensures an additional neck seal of the hood.

During use head straps and neck string can be readjusted to ensure a consistent proper fit of the mask-hood.

In order to check the mask-to-face tightness a leak test must be performed before each use.

⚠ WARNING!

Ensure that the top of the mask seal only lies on the user's forehead. Hair should not be between the mask's seal and the user's skin.

The mask could otherwise leak. This danger also exists for instance for mask wearers with beards or deep scars in the sealing area.

Failure to follow this warning can result in serious personal injury or death.

⚠ WARNING!

In order to guarantee a proper fit for those wearing glasses, the mask specific spectacle kit must be worn since ordinary glasses cannot be worn under the mask.

Failure to follow this warning can result in serious personal injury or death.



21. Seal the mask connector with the bowl of your hand.

22. Test tightness by inhaling and exhaling. Whilst doing so:

When inhaling there must be negative pressure, no inflowing air should be noticeable.

23. If necessary retighten the straps.

If the leak test fails the mask must not be used.



24. Insert the LGDV into the adapter of the mask until it distinctly snaps into place.

25. To activate, inhale once forcefully or push flush button.



Device is ready for use.

4.4 During Use

WARNING!

- Observe the pressure gauge of SCBA on regular intervals.
- Do not remove shoulder strap.
- For devices with warning signal, the warning signal is activated if the air supply in the cylinder is reduced. In this case leave the hazardous area and return to fresh air immediately, there might be danger of air deficiency.
- Take care not to pinch any fingers when disconnecting the combination valve assembly.

Failure to follow this warning can result in serious personal injury or death.



- If medium pressure hose is in the way, slide it under shoulder strap.

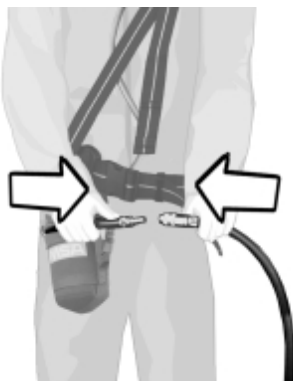

- Depending on configuration:
Connect the airline attachment hose to the compressed air supply hose (coupling for long plug nipple) or to an external air supply (coupling for short plug nipple) in escape situations.



- If necessary: Disconnection of combination valve assembly from harness holster in confined spaces.
1. Keep push button of the holster pressed while removing the combination valve assembly from holster.
 2. For reconnection slide disc of the combination valve assembly into the slot of the holster.

4.5 PremAire Combination Escape according to EN 402 and PremAire Combination Escape/EEBD according to EN 402, ISO 23269-1

The devices according to EN 402 and ISO 23269-1 are designed for escape situations only.

The device has to be donned upfront to be prepared for a potential escape situation or immediately when necessary (see chapter [4.2 Donning as Escape device](#)). The user has to escape to a safe place following the local requirements.

The device with LGDV and T-piece according to EN 402 is only certified for emergency air supply situations and not certified for use as an airline breathing apparatus.

The device is equipped with a connection for an external air supply. This enables a connection to a rescue airline e. g. in "safe havens". The operation pressure of the compressed air feeding hose should be between 6.0 bar and 8.5 bar. The air quality has to be in accordance with EN 12021.

If the device is connected to a rescue airline it is possible to save the remaining cylinder pressure, by closing the cylinder valve (with the handwheel) of the combination valve assembly and to breathe only through the airline connection. It is necessary to reopen the handwheel before disconnecting the rescue airline to ensure breathable air supply.

4.6 PremAire Combination Airline/Escape according to EN 14593-1/EN 402 and PremAire Combination Airline/Escape/EEBD according to EN 14593-1/EN 402/ISO 23269-1

The devices are compressed airline breathing apparatus for use in work situations and enable the user to escape if the air supply from the working airline is not sufficient or blocked.

Working device

In case of normal working operation the device has to be donned according to chapter [4.3 Donning as Working device](#). During donning the user is still in a safe area and can breathe the ambient air. It is possible to don first the complete harness.

The ASV has to be connected to the Escape device and the airline.

The operation pressure of the working airline has to be between 6.0 bar and 8.5 bar. There must be effective water separation to reduce the dew-point and prevent freezing in the apparatus (maximum water content requirement as defined in EN 12021).

After the tightness check of the device and the facepiece the handwheel of the cylinder valve of the PremAire Combination has to be opened completely.

Compressed air from the working airline is supplied when connecting the LGDV to the facepiece.

Escape device

The ASV switches over automatically to the Escape device if the pressure in the working airline drops under 4.3 bar or is reduced abruptly. The ASV with warning signal provides an acoustic warning if it has switched to compressed air delivery from the Escape device. The switching of the Automatic Switch Valves ASV does not cause any reduction of breathable air supply for the user.

If the ASV has switched over to Escape device and the warning signal sounds the user has to escape to a safe place following the local requirements. If necessary the working airline can be disconnected to escape.

Of course it is possible to connect the device to a rescue airline.

4.7 PremAire Combination/SCBA according to EN 14593-1/EN 137 Type 1

The PremAire Combination according to EN 14593-1/EN 137 Type 1 is a compressed airline breathing apparatus for use in work situations.

Working device

In case of normal working operation the device has to be donned according to chapter [4.3 Donning as Working device](#). During donning the user is still in a safe area and can breathe the ambient air. It is possible to don first the complete harness.

The ASV has to be connected to the Escape device and the airline.

The operation pressure of the working airline has to be between 6.0 bar and 8.5 bar. There must be effective water separation to reduce the dew-point and prevent freezing in the apparatus (maximum water content requirement as defined in EN 12021).

After the tightness check of the device and the facepiece the handwheel of the cylinder valve of the PremAire Combination has to be opened completely.

Compressed air from the working airline is supplied when connecting the LGDV to the facepiece.

The ASV switches over to the SCBA if the pressure in the working airline drops under 4.3 bar or is reduced abruptly. The ASV with warning signal provides an acoustic warning if it is switched to compressed air delivery from the SCBA. The switching of the ASV does not cause any reduction of breathable air supply for the user.

If the ASV has switched over to SCBA and the warning signal sounds the user can continue to work breathing air from the SCBA. The pressure gauge on the valve assembly must be observed to ensure sufficient air flow to exit the work area. It is possible to disconnect the working airline while breathing out of the SCBA.

4.8 Refilling the Cylinder via MSA Quick-Fill System (if applicable)

All PremAire devices can be equipped with a Quick-Fill adapter for the MSA Quick-Fill System.

WARNING!

- Depending on the pressure and the volume of cascade cylinders used, the achievable filling pressure and service duration will vary!
- Never refill cylinders via Quick-Fill system in explosive atmospheres if there is a danger to exceed the permissible temperature of >85 °C on any component of the device and Quick-Fill system.

Failure to follow this warning can result in serious personal injury or death.

CAUTION!

Applicable national regulations must be observed.

Failure to follow this caution can result in minor or moderate injury.

1. Remove Quick-Fill protection cap.
2. Connect filling hose.

3. Fill cylinder.
Watch the pressure gauge.
4. Disconnect filling hose.
5. Put on Quick-Fill protection cap.

For additional information see chapter [6.2 MSA Quick-Fill System \(if applicable\)](#).

4.9 After Use

Disconnecting the LGDV

1. Disconnect the LGDV by pressing both operating buttons at once.

Removing the Facepiece

1. Loosen the head harness, press the buckles forwards using your thumbs.



3S masks: Do not grip the mask by the exhalation valve!

Mask-hood: Open the neck string first!

2. Grip the facepiece by the connector and pull off backwards over your head.

Disconnecting the Harness

1. Close cylinder valve with the handwheel.
2. Disconnect the waist belt buckle.
3. Loosen the shoulder adjustment buckle.
4. Remove complete device.

WARNING!

When disconnecting the compressed air hose ends while they are under pressure the plug nipple side must be held firmly. The escaping air could otherwise cause the hose to be propelled in an uncontrolled way (especially long hoses).

Failure to follow this warning can result in serious personal injury or death.

WARNING!

Do not throw off the device. This could damage the valve and any remaining compressed air could escape suddenly. This could cause fatal injury to you or to any bystanders.

Failure to follow this warning can result in serious personal injury or death.

5 Cleaning

⚠ CAUTION!

For cleaning, do not use organic solvents, such as nitrous dilution, alcohol, spirits, gasoline, trichloroethylene, etc.
Failure to follow this caution can result in minor or moderate injury.

⚠ CAUTION!

Clean the device immediately after using it in salty atmospheres, all salt must be removed to avoid damage to the device.

Failure to follow this caution can result in minor or moderate injury.

Cleaning, light Soiling

1. Clean device manually using a brush, damp cloth or similar.
2. If necessary, use soap and water.
3. Air-dry device completely.

Cleaning, heavy Soiling

1. Disconnect LGDV.
2. Separate harness assembly and cylinder cover from other device components.



3. Remove the shoulder strap from the slots of the belt holding plate:
 - a. Push slider through belt holding plate.
 - b. Separate shoulder strap by pulling the strap.

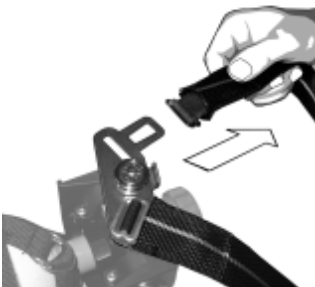

⚠ WARNING!

Do not remove the screw holding the belt holding plate.

Failure to follow this warning can result in serious personal injury or death.

4. Clean harness assembly and cylinder cover in a

suitable washing machine at max. 40 °C.

5. Clean hoses, cylinder with combination valve assembly preferably by hand with a damp cloth.

CAUTION!

Do not submerge the combination valve assembly.

Failure to follow this caution can result in minor or moderate injury.

6. Completely dry all device components in a drying cabinet at max. 50 °C.

5.1 Cleaning/Disinfection Facepiece

The cleaning/disinfection of the facepieces is performed in accordance with the cleaning intervals in the mask manual or mask-hood manual. For cleaning/disinfection instructions see mask manual or mask-hood manual.

5.2 Lung Governed Demand Valve

For cleaning/disinfection instructions, see LGDV manual.

5.3 Compressed Air Cylinder

Cleaning instructions of the cylinder:

WARNING!

While cleaning make sure that no water penetrates the combination valve assembly.

Failure to follow this warning can result in serious personal injury or death.

- The surface cleaning can be made with water and, if necessary, a soap additive.
- Chemical cleaning detergents and solvents must not be used, using those detergents could affect the overwrap of Composite Cylinders.

Drying instructions of the cylinder:

- Use or fit only dry components.
- Compressed air cylinders without valve may be dried internally in an air circulation drying cabinet (for max. permissible temperature see cylinder label).

CAUTION!

Cylinders must not be dried in a vacuum drying cabinet, a collapse of liners is possible!

Failure to follow this caution can result in minor or moderate injury.

6 Filling the Compressed Air Cylinder

WARNING!

The permissible operating temperature of <85 °C (T6) must implicitly be adhered to. Never take a device with a temperature >85 °C into a explosive atmosphere!

Improper handling of compressed air cylinders can have fatal consequences for you and others.

Failure to follow this warning can result in serious personal injury or death.

WARNING!

Applicable national regulations must be observed.

Only breathing air in accordance with EN 12021 or better may be used.

Compressors and filling devices may only be operated by trained personnel. All warning and safety instructions must be observed.

Failure to follow this warning can result in serious personal injury or death.

Cylinders must only be filled if

- the cylinder is not damaged.
- they have the surveyor test mark and the test period indication.
- they have not exceed the test period marked on the cylinder.

It is not necessary to take the compressed air cylinder out of the cylinder cover for refilling.

Keep the handwheel closed for refilling the cylinder. Opening with the handwheel is not required.

CAUTION!

As a result of the air compression cylinders are getting hot during the filling cycle. Since composite materials are good insulators the heat generated takes longer to dissipate on the cylinder surface. The temperatures may reach approx. 70 °C. After returning to ambient temperatures check if the maximum filling pressure is reached, if necessary, top up pressure.

After filling, the cylinders must be checked for tightness. For storage, put sealing plug into valve connection, check cylinders for pressure in regular intervals.

Failure to follow this caution can result in minor or moderate injury.

Compressed air cylinders filled with air exceeding marginally the permissible humidity levels (breathing air to EN 12021) shall be flushed with dry compressor air meeting the requirements of EN 12021 (observe the compressor filter condition, if necessary, exchange the filters):

1. Fill air cylinder to approx. 50 % service pressure with air meeting the standard requirements, discharge air slowly to approx. 30 bar.
2. Fill cylinder again to service pressure and discharge again slowly.
3. Fill cylinder, cool down to room temperature, check air quality. If necessary, discharge and refill again, until the limit values are met.

6.1 Filling Connector 300 bar

The device is equipped with a 300 bar G 5/8" thread filling connector according to EN 144-2.

1. Connect the filling connector of the device to a 300 bar or 200 bar filling connection and fill to minimum 300 bar or 200 bar (rated service duration for Escape devices, see chapter 1.1 Correct Use). Follow the compressor instructions.

6.2 MSA Quick-Fill System (if applicable)

If the device is equipped with an MSA Quick-Fill system:

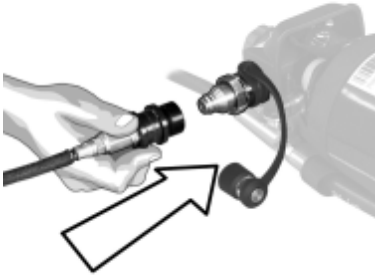

1. Remove Quick-Fill protection cap.
2. Connect the filling hose to the Quick-Fill adapter.

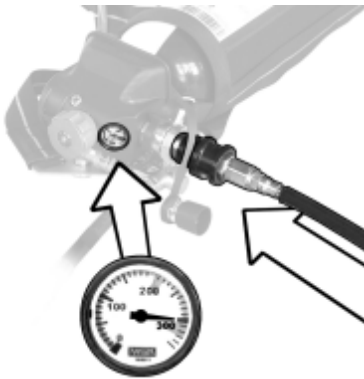

3. Fill to the nominal pressure of minimum 300 bar or 200 bar.
4. Disconnect the filling hose.

⚠ WARNING!

Ensure that the filled cylinder has achieved the pressure necessary to ensure service duration.

Failure to follow this warning can result in serious personal injury or death.

Quick-Fill adapter

Filling hose coupling

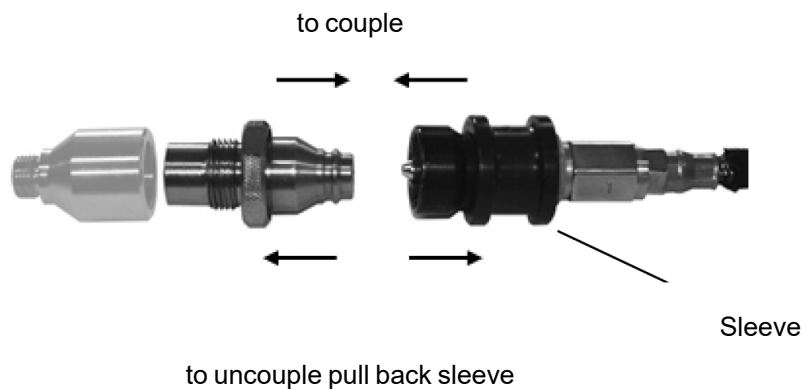

⚠ CAUTION!

Quick-Fill couplings are precision components!

Immediately after use the couplings should be closed with the protection caps to prevent dirt and dust from entering and to assure that the couplings can continue to be used easily and safely.

Failure to follow this caution can result in minor or moderate injury.



5. After filling close the coupling with the Quick-Fill protection cap.

6.3 After Filling

As a result of the air compression cylinders are getting hot during the filling cycle. Since composite materials are good insulators, the heat generated takes longer to dissipate on the cylinder surface. The temperatures may reach approx. 70 °C.

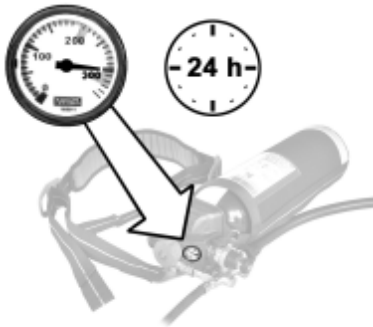

1. After returning to ambient temperatures check if the minimum filling pressure of 300 bar or 200 bar is reached.

If necessary, top up pressure.

2. After filling, the cylinder must be checked for tightness.

7 Sight, Function and Tightness Check

After all components of the device have been cleaned, disinfected and dried, the device has to be completed and connected.

For necessary checks of the LGDV before connection, see LGDV manual.

For necessary checks of the facepiece before connection, see mask manual.

1. Fill the cylinder and compare the pressure value on the pressure gauge with the pressure value shown by the filling system.

The maximum permissible deviation is ± 20 bar.

2. Open cylinder valve and pressurise the system.
3. Carefully listen for leakage in the pneumatic system.
4. Close cylinder valve.
5. If applicable: If device is equipped with a warning signal, check warning signal:
 - a. Close exit port of LGDV partially by hand to control the air flow.
 - b. Carefully activate flush mode of LGDV.
 - c. Check if warning signal activates.
6. Depressurise the system by activating the flush mode of the LGDV.
7. Switch off the positive pressure function of the LGDV with the operation button.

8 Maintenance

This device should be regularly checked and serviced by trained specialists. Inspection and service records must be maintained. Always use original parts from MSA.

Repairs and maintenance must be carried out only by authorised service centres or by MSA. Changes to devices or components are not permitted and will result in loss of approval.

MSA is liable only for maintenance and repairs carried out by MSA.

Inspect the entire device after it is cleaned and disinfected.

WARNING!

If the device does not meet any of the following inspections, it must be removed from service.

Failure to follow this warning can result in serious personal injury or death.

WARNING!

Take care not to damage the device during carriage or transport.

Failure to follow this warning can result in serious personal injury or death.

8.1 Maintenance Intervals

Component	Work to be performed	After use	Annually	Every 10 years*
PremAire Combination	Cleaning	X	X	
	Sight, function and tightness check	X	X	
	Overhaul			X or after 540 hours of active use or after 2000 filling cycles
LGDV/facepiece	See LGDV/mask manual/cylinder/Quick-Fill (optional) operating manuals.			
Cylinder	Applicable national regulations must be observed.			

* Every 5 years in Germany according to BGR 190

8.2 Facepiece

See position 1, [Figure 1](#).

For detailed instructions see mask manual or mask-hood manual.

8.3 Lung Governed Demand Valve

See position 2a, 2b and 2c, [Figure 1](#).

1. Verify that all hoses are properly connected and check them carefully for cracks.

For maintenance of the LGDV, see LGDV manual.

8.4 Combination Valve Assembly/Compressed Air Cylinder

See position 9 and 7, [Figure 1](#).

1. Inspect the combination valve assembly for signs of damage.
2. Inspect the cylinder body for cracks, dents, weakened areas, corrosive agent, causing the fibers to break or peel, or signs of heat-related damage.
3. Perform checks on the compressed air cylinders in accordance with the national regulations.
4. Verify that all hoses are properly connected.
5. Inspect the filling connector. Verify that the respective connector protection cap or a Quick-Fill adapter (if applicable) with Quick-Fill protection cap is properly connected.

8.5 Harness Assembly

See position 5a, 5b, 5c and 13, [Figure 1](#) .

1. Inspect all harness components for cuts, tears, abrasion or signs of heat or chemically-related damage. Verify that the cylinder cover securely retains the cylinder.

8.6 Quick-Fill Adapter (if Applicable)

See position 12, [Figure 1](#) .

The couplings and plugs of the Quick-Fill System have to be tested on function and tightness annually. If necessary the parts have to be replaced. These tests may only be performed with air and an operating pressure of 300 bar.

8.7 Compressed Air Supply Hose

See position 14, [Figure 1](#) .

Compressed air supply hoses must be checked at regular intervals and replaced if necessary, depending on the local conditions.

9 Packaging and Storage

9.1 Ready to Use Storage

If a storage container or cover is used to protect against dust, oil, mist or climate it should be possible to check the pressure gauge to ensure a fully pressurised cylinder and to identify unauthorised opening.

Device used for Escape Purposes

The device should be stored in a way that it is readily available in any emergency situation and can be donned in 20 sec (see chapter [4.2 Donning as Escape device](#)).

9.2 Storage Conditions

Store the device always in such a manner that the hoses are not kinked and squeezed. Store in a dry place, free from dust and dirt, at a storage temperature between -15 °C and + 25 °C. Protect device against direct sunlight. Do not store the device within or near an area where the device can or might be exposed to any substances that will attack any part of the device, causing the device NOT to perform as designed and approved.

To ensure readiness for use of escape devices according to EN 402, the devices must NOT be stored in any container. The plastic protective case (585 x 310 x 270 mm) is only for transportation purposes.

For additional storage information, see the manuals for the parts of the device.

10 Technical Data

Operating pressure	200/300 bar
Warning signal activation pressure (if applicable)	100 bar +10 bar
Working pressure range of combination valve assembly	4.0 to 8.5 bar
Working pressure of the airline system	6.0 bar to 8.5 bar
Permissible operating temperature	see table in chapter 11 Marking/Certification
Storage temperature range	-15 °C to +25 °C
Shelf life of cylinders	
Steel	unlimited
Composite	15 years (see label)

Weight (complete device)	Depending on configuration:		
with 1.1 l 300 bar composite cylinder (empty)	4.1 kg	to	4.9 kg
with 1.1 l 300 bar composite cylinder (full)	4.5 kg	to	5.3 kg
with 2 l 300 bar composite cylinder (empty)	4.5 kg	to	5.3 kg
with 2 l 300 bar composite cylinder (full)	5.2 kg	to	6.0 kg
with 2 l 300 bar steel cylinder (empty)	6.7 kg	to	7.5 kg
with 2 l 300 bar steel cylinder (full)	7.4 kg	to	8.2 kg
with 3 l 300 bar composite cylinder (empty)	5.0 kg	to	5.8 kg
with 3 l 300 bar composite cylinder (full)	6.0 kg	to	6.8 kg

11 Marking/Certification

Apparat Card PremAire Combination

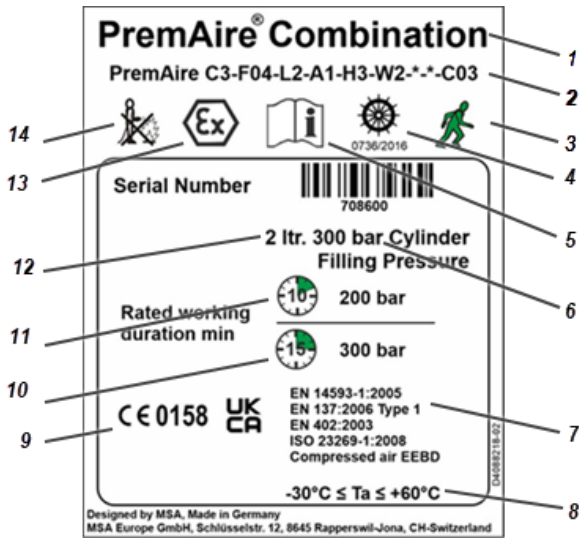

Figure 4 Apparat Card PremAire Combination

- | | | | |
|---|--|----|---|
| 1 | Product name | 8 | Operating temperature range |
| 2 | ATO Code (description see table) | 9 | CE/UKCA-marking with notified body number |
| 3 | Device is suitable for self-rescue according to EN 402 | 10 | Operating time in minutes at 300 bar filling pressure of the cylinder (escape time) |
| 4 | ISO 23269-1:2008 | 11 | Operating time in minutes at 200 bar filling pressure of the cylinder (escape time) |
| 5 | Manual | 12 | Cylinder size |
| 6 | Maximum cylinder pressure | 13 | ATEX certification |
| 7 | Certification | 14 | The device must not be used for fire fighting. |

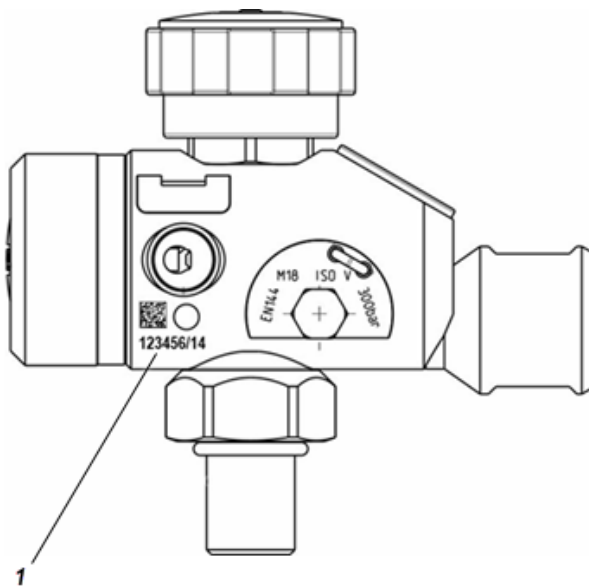

Figure 5 Valve

- 1 Serial No. / Year of manufacture

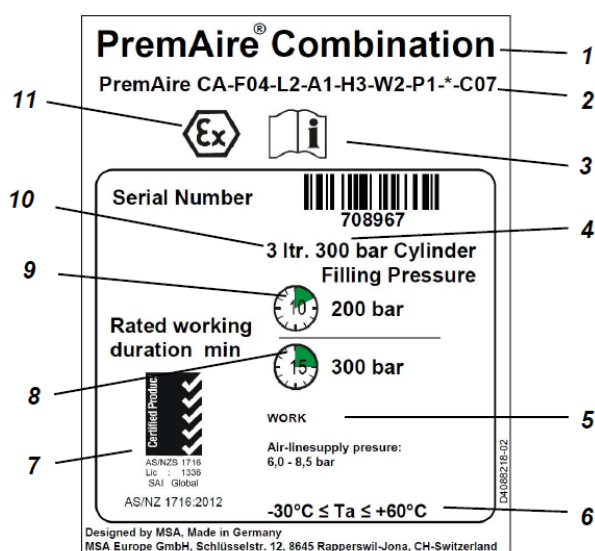

Figure 6 Apparat Card PremAire Combination according to AS/NZS 1716:2012

- | | | | |
|---|--|----|---|
| 1 | Product name | 7 | Certification |
| 2 | ATO Code (description see below in " ATEX Classification of the Components/ATO-Code Description ") | 8 | Operating time in minutes at 300 bar filling pressure of the cylinder (escape time) |
| 3 | Manual | 9 | Operating time in minutes at 200 bar filling pressure of the cylinder (escape time) |
| 4 | Maximum cylinder pressure | 10 | Cylinder size |
| 5 | Type | 11 | ATEX certification |
| 6 | Operating temperature range | | |

Label Marking Compressed Air Cylinder

Markings on Label	Explanation
EN	Thread identification
x, x kg	Weight of empty cylinder (without valve), kg
V x, xL	Water capacity, litres
FP xxx bei xx °C	Service pressure at xx °C
TS-xx °C/ +xx °C	Operating temperature range (-/+), °C for assembly group (cylinder with valve)
	Operating temperature range (-/+), °C for assembly group (without valve)
PS xxx bar bei xx °C	maximum permissible pressure at xx °C
PS xxx bar	Test pressure (1.5 x filling pressure)
FIN xxxx/xx	Cylinder life in year and month (if cylinder life is limited)
Baugruppe Atemschutzgerät CE 2266	Marking according to Directive 2014/68/EU by DEKRA
CExxx	Cylinder manufacturer marking according to Directive 2014/68/EU
EN 12245	Design standard cylinders
MSA	Manufacturer of assembled group (Cylinder and cylinder valve)
xxxx/xx	Periodic inspection in Year and Month
Serial Number	
Barcode	
Hazardous Material Symbol and UN 1002	In conformity with GGVSE/ADR (Road and rail transport of hazardous materials, Germany and Europe)
Name of cylinder manufacturer	

ASV Marking

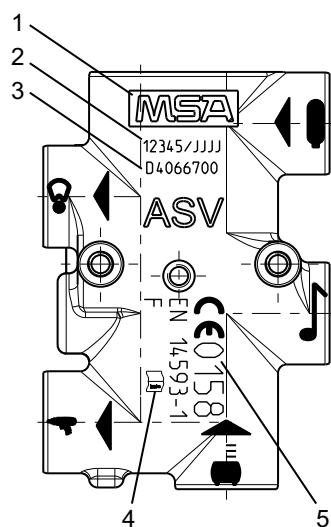



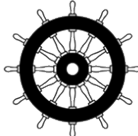

Figure 7 ASV - Automatic Switch Valve

- 1 Manufacturer 4 Icon for „Read the Manual“
 2 Serial No. / Year 5 Certification
 3 Material No.

Certification

Approvals		The device conforms to the Regulation (EU) 2016/425. It is in accordance with harmonised/designated standards EN137:2006 Type 1 and/or EN 14593-1:2018 and/or EN 402:2003 and/or ISO 23269-2:2011, for the partly extended temperature range from -30/-40 °C to +60 °C.
	0158	DEKRA Testing and Certification GmbH, Dinnendahlstr. 9, 44809 Bochum, Germany
		ATEX Certification
 AS/NZS 1716 Lic : 1338 SAI Global		AS/NZS 1716:2012 (tested by DEKRA Testing and Certification GmbH)
	0736	2014/90/EU amended by (EU) 2020/1170
		BG Verkehr, Dienststelle Schiffssicherheit, Brandstwiete 1, 20457 Hamburg, Germany

The Declaration of Conformity can be found under the following link: <https://MSAsafety.com/DoC>.

ATEX Classification of the Components/ATO-Code Description

ATO	Description	ATEX
Carrying system		
C1	PremAire Combination Escape	I M1, II 1G IIB, II 2G IIC, II 1D
C2	PremAire Combination Airline/Escape	I M1, II 1G IIB, II 2G IIC, II 1D
C3	PremAire Combination Airline/SCBA	I M1, II 1G IIB, II 2G IIC, II 1D
C5	PremAire Combination Escape/EEBD	I M1, II 1G IIB, II 2G IIC, II 1D
C6	PremAire Combination Airline/Escape/EEBD	I M1, II 1G IIB, II 2G IIC, II 1D
Masks		
F03	3S-PS-V-MaXX (CIS) (-40 °C)	I M1, II 1G IIB, II 2G IIC, II 1D
F04	3S-PS-MaXX (-30 °C)	I M1, II 2G IIA, II 3G IIC, II 1D
F05	UE-PS-MaXX (CIS) (-40 °C)	I M1, II 1G IIB, II 2G IIC, II 1D
F06	UE-PS-MaXX (-30 °C)	I M1, II 1G IIB, II 2G IIC, II 1D
F08	3S-PS-V-MaXX small (CIS) (-40 °C)	I M1, II 1G IIB, II 2G IIC, II 1D
F11	3S-PS-IH Basic (Size M)	I M1, II 2G IIA, II 3G IIC, II 1D
F12	3S-PS-IH Basic small	I M1, II 2G IIA, II 3G IIC, II 1D
F13	3S-PF-ESA Full Face Mask	I M1, II 2G IIA, II 3G IIC, II 1D
F14	Mask-Hood-PS-MaXX	I M1, II 1G IIB, II 2G IIC, II 1D
Components		
L2	AS	I M1, II 1G IIC, II 1D
L3	AS Bypass	I M1, II 1G IIC, II 1D
L4	ESA	I M1, II 1G IIC, II 1D
T1	T-piece with coupling Type E (Cejn)	I M1, II 1G IIC, II 1D
A1	ASV with coupling Typ E (Cejn)	I M1, II 2G IIA, II 3G IIC, II 1D
H3	Medium pressure hose, Combination	I M1, II 1G IIC, II 1D
H4	Medium pressure hose with Y-piece, Combination	I M1, II 1G IIC, II 1D
W2	WS 100 bar	I M1, II 1G IIB, II 2G IIC, II 1D
W3	no warning signal	I M1, II 1G IIC, II 1D
P1	Excess Flow Valve	-
P2	water protection tube	-
Q	Quick-Fill	I M1, II 1G IIC, II 1D
Cylinder size		
C01	2 l, 300 bar, steel (empty)	I M1, II 1G IIC, II 1D
C02	2 l, 300 bar, steel (charged)	I M1, II 1G IIC, II 1D
C03	2 l, 300 bar, composite, L19C (empty)	I M1, II 1G IIC, II 1D
C04	2 l, 300 bar, composite, L19C (charged)	I M1, II 1G IIC, II 1D

ATO	Description	ATEX
C07	3 l, 300 bar, composite, L29C (empty)	I M1, II 1G IIC, II 1D
C08	3 l, 300 bar, composite, L29C (charged)	I M1, II 1G IIC, II 1D
C09	1,1 l, 300 bar, composite, P12H (empty)	I M1, II 1G IIC, II 1D
C10	1,1 l, 300 bar, composite, P12H (charged)	I M1, II 1G IIC, II 1D
Accessories		
	Polster Waist Belt	I M1, II 1G IIB, II 2G IIC, II 1D
	Extension Belt	I M1, II 1G IIC, II 1D
	Leg Strap	I M1, II 1G IIC, II 1D
	Box	II 1D
	Air supply line antistatic, 5 m	I M1, II 1G IIC, II 1D
	Compressed air supply hose, 10 m	I M1, II 1G IIC, II 1D
	Compressed air supply hose, 20 m	I M1, II 1G IIC, II 1D
	Compressed air supply hose, 30 m	I M1, II 1G IIC, II 1D
	Compressed air supply hose, 50 m	I M1, II 1G IIC, II 1D
	PremAire Exchange Cylinder (KZ)	I M1, II 1G IIB T6, II 1D
	AutoMaXX-AS Demand Valve Holder	I M1, II 1G IIC, II 1D
	AutoMaXX-ESA Demand Valve Holder	I M1, II 1D, II 1G II B, II 2G II C

The ATEX class of the components of the device has to be regarded.
The lowest class sets the limit.

Facepieces



The mask determines the temperature range for the complete device.

Description	Mat. No.	approved temperatures
3S-PS-V-MaXX (CIS)	10098236	-40 °C
3S-PS-MaXX full face mask	10031422	-30 °C
Ultra Elite PS-MaXX (CIS)	10098238	-40 °C
Ultra Elite PS-MaXX full face mask	10031385	-30 °C
3S-PS-V-MaXX full face mask, small	10153912	-40 °C
3S-PS-IH-MaXX Basic	10152373	-40 °C
3S-PS-IH-MaXX Basic, small	10153914	-40 °C
3S-PF-ESA full face mask	10031394	-30 °C
PremAire Mask-Hood-PS-MaXX	10175059	-40 °C

12 Ordering Information

Replacement Parts

Description	Part No.
Threaded plug 5/8 x 14, pack of 10	10053343
AutoMaXX-AS,T, PremAire Combination	10127216-SP
AutoMaXX-AS, Y-Piece-FF, KZ SP	10127837-SP
AutoMaxx-AS, Plug, PremAire Combination	10157898-SP
AutoMaXX AS-B, Plug, PremAire Combination	10159966-SP
AutoMaXX AS-B, Y-FF, PremAire Combination	10162236-SP
AutoMaXX-AS-B,T, PremAire Combination	10165720-SP
AutoMaXX-ESA, Plug, PremAire Combination	10170588-SP
AutoMaXX-ESA, T, PremAire Combination	10170589-SP
AutoMaXX-ESA, Y-FF, PremAire Combination	10171034-SP
Protection cap nipple Ø12, flame resistant, blue (pack of 5)	10068513-SP
ASV, warning signal, assembly, PremAire	10153313-SP
AutoMaXX-AS Demand valve holder, pack of 5	10118878-SP
AutoMaXX-ESA Demand Valve Holder	10078512
Waist Belt, PremAire Combination	10124522-SP
PremAire Combination holster assembly	10124536-SP
PremAire Combination shoulder strap	10124538-SP
Cylinder cover 3 I, PremAire	10125310-SP
Cylinder cover 2 I, PremAire	10128070-SP
Cylinder cover 1.1 I, PremAire	10154153-SP
3S-PS-V-MaXX (CIS)	10098236
3S-PS-MaXX full face mask	10031422
Ultra Elite PS-MaXX (CIS)	10098238
Ultra Elite PS-MaXX full face mask	10031385
3S-PS-V-MaXX full face mask, small	10153912
3S-PS-IH-MaXX Basic	10152373
3S-PS-IH-MaXX Basic, small	10153914
3S-PF-ESA full face mask	10031394
PremAire Mask-Hood-PS-MaXX	10175059
Compressed air supply hose, 5 m	D4066847
Compressed air supply hose, 10 m	D4066848
Compressed air supply hose, 20 m	D4066849
Compressed air supply hose, 30 m	10152521
Compressed air supply hose, 50 m	10012120

Accessories

Description	Part No.
PremAire Quick-Fill connector	10127956-SP
Quick-Fill coupling protector (male)	D4075962-SP
Waist pad	10124528-SP
Extension belt	10124537-SP
Protective Case, 585 X 310 X 270, plastic	10126349-SP
Leg strap assembly, PremAire Combination (pack of 5)	10148378-SP
PremAire Exchange Cylinder (KZ)	10128702