



®

Dongguan Anci Electronic Technology Co., Ltd.

Add.: 1-2 Floor, Building A, No.11, Headquarters 2 Road, Songshan Lake
Hi-tech Industrial Development Zone, Dongguan City, Guangdong Pr., China.

Tel: 86 -769 -8507 5888 Fax: 86 -769 -8507 5898 Web: www.anci.com

ATTESTATION OF CONFORMITY

Attestation No.: 21AE030251E001

This Attestation of Conformity is hereby issued to the product designated below

Report No. : EA21030251E01001

Applicant : Ledlenser Corporation Ltd.

Address : No.25,Yudong 1Road,Dongcheng Town,Yangdong District,
Yangjiang City,GD,529931,China

Manufacturer : Ledlenser Corporation Ltd.

Address : No.25,Yudong 1Road,Dongcheng Town,Yangdong District,
Yangjiang City,GD,529931,China

Description of Product : Keychain light

Model No. : K6R

Input Rating : Battery 3.7Vdc, 550mAh, 2.03Wh

Test Standards : EN IEC 55015:2019/A11:2020
EN 61547:2009

This Attestation of Conformity is based on evaluation of a sample of the above mentioned product. Technical report and documentation are at the license Holder's disposal. This is to certify that the tested sample is in conformity with the Council Directive 2014/30/EU, referred to as the EMC. It is possible to use CE marking to demonstrate the conformity with this EMC Directive.



Test Laboratory

Alan He
EMC Manager
Date of Issue: March 25, 2021

This Attestation of Conformity is based on a single evaluation of the submitted sample(s) of the above mentioned product. It does not imply an assessment of the whole production and other relevant Directives have to be observed.

EMC TEST REPORT



For Electromagnetic Interference of

Report Reference No.:	EA21030251E01001
Engineer (name + signature).....:	Wite Chen
Reviewed by (name + signature)	Tiger Xu
Approved by (name + signature).....:	Alan He
Date of Receipt of EUT	March 15, 2021
Date of Test	March 15, 2021 to March 25, 2021
Date of issue	March 25, 2021
Testing Laboratory.....:	Dong Guan Anci Electronic Technology Co., Ltd
Address	1-2 Floor, Building A, No.11, Headquarters 2 Road, Songshan Lake Hi-tech Industrial Development Zone, Dongguan City, Guangdong Pr., China.
Laboratory location.....:	EMC Laboratory
Applicant's name	Ledlenser Corporation Ltd.
Address	No.25,Yudong 1Road,Dongcheng Town,Yangdong District, Yangjiang City,GD,529931,China
Manufacturer	Ledlenser Corporation Ltd.
Address	No.25,Yudong 1Road,Dongcheng Town,Yangdong District, Yangjiang City,GD,529931,China
First Factory's name.....:	Yangjiang Brighter Lighting Co., Ltd.
Address.....:	Industrial Avenue, Wanxiang Industrial Park, Beiguan Town, Yangdong district, Yangjiang, Guangdong, China.



Test specification:

EUT description	: Keychain light
Trade Mark.....	:  LEDLENSER
Model/Type reference	: K6R
Test Sample.....	: K6R
Ratings.....	: Battery 3.7Vdc, 550mAh, 2.03Wh
Test Voltage.....	: DC 3.7V
Standards.....	: EN IEC 55015:2019/A11:2020 EN 61547:2009

The device described above was tested by Dong Guan Anci Electronic Technology Co., Ltd. to determine the maximum emission levels emanated from the device and severity levels of the device endure and its performance criterion. The measurement results are contained in this test report and Dong Guan Anci Electronic Technology Co., Ltd. assumes full responsibility for the accuracy and completeness of these measurements. This report shows the EUT is technically compliance with the above official standards.

This report applies to the above sample only and shall not be reproduced in part without written approval of Dong Guan Anci Electronic Technology Co., Ltd.

Table of Contents	Page
1 . GENERAL INFORMATION	5
1.1 PRODUCT INFORMATION	5
1.2 Details about the Test Laboratory	6
2 . SUMMARY OF TEST RESULTS	8
2.1 MEASUREMENT UNCERTAINTY	9
2.2 DESCRIPTION OF TEST MODES	9
2.3 BLOCK DIGRAM SHOWING THE CONFIGURATION OF SYSTEM TESTED	10
3 . EMISSION TEST	11
3.1 Conducted Disturbance at Mains Terminals	11
3.1.1 LIMIT OF CONDUCTED EMISSION(MAINS PORT)	11
3.1.2 MEASUREMENT INSTRUMENTS LIST	11
3.1.3 TEST PROCEDURE	12
3.1.4 DEVIATION FROM TEST STANDARD	12
3.1.5 TEST SETUP	12
3.1.6 EUT OPERATING CONDITIONS	12
3.1.7 TEST RESULTS	13
3.2 Specification Limits	14
3.2.2 MEASUREMENT INSTRUMENTS LIST	14
3.2.3 TEST PROCEDURE	14
3.2.4 TEST SETUP	15
3.2.5 EUT OPERATING CONDITIONS	15
3.2.6 TEST RESULTS	15
3.3 Radiated Disturbance (30MHz to 1000MHz)	16
3.3.1 LIMITS OF RADIATED EMISSION MEASUREMENT	16
3.3.2 MEASUREMENT INSTRUMENTS LIST	16
3.3.3 TEST PROCEDURE	16
3.3.4 DEVIATION FROM TEST STANDARD	17
3.3.5 TEST SETUP	18
3.3.6 EUT OPERATING CONDITIONS	18
3.3.7 TEST RESULTS	19
3.4 measurement emission measurement	20
3.4.1 MEASUREMENT INSTRUMENTS LIST	24
3.4.2 LIMITS OF MAGNETIC EMISSION MEASUREMENT	24
3.4.3 LARGE LOOP ANTENNA SETUP DIAGRAM	25
3.4.4 OPERATING CONDITIONS OF THE EUT	26
3.4.5 MAGNETIC EMISSION DATA	26
3.4.6 TEST RESULTS	27
4 . EMC IMMUNITY TEST	31
4.1 STANDARD COMPLIANCE/SERVIRITY LEVEL/CRITERIA	31

Table of Contents	Page
4.2 GENERAL PERFORMANCE CRITERIA	32
4.3 GENERAL PERFORMANCE CRITERIA TEST SETUP	32
4.4 ESD TESTING	33
4.4.1 TEST SPECIFICATION	33
4.4.2 MEASUREMENT INSTRUMENTS	33
4.4.3 TEST PROCEDURE	33
4.4.4 DEVIATION FROM TEST STANDARD	33
4.4.5 TEST SETUP	34
4.4.6 TEST RESULTS	35
4.5 RS TESTING	36
4.5.1 TEST SPECIFICATION	36
4.5.2 MEASUREMENT INSTRUMENTS	36
4.5.3 TEST PROCEDURE	36
4.5.4 DEVIATION FROM TEST STANDARD	36
4.5.5 TEST SETUP	37
4.5.6 TEST RESULTS	38
5. ATTACHMENT	39
5.1 EUT Test Photo	39
5.2 EUT Photo	41

1. GENERAL INFORMATION

1.1 PRODUCT INFORMATION

1. The equipment is Keychain light Luminaires for the use in lighting equipment.
2. Except for the color difference, the rest are the same structure.
3. This test report only reflects the worst data of the test mode.

All tests was performed on model K6R.

The EUT passed the test.

1.2 Details about the Test Laboratory

Test Site 1:

Company name: Dongguan Anci Electronic Technology Co., Ltd.

Address: 1-2 Floor, Building A, No.11, Headquarters 2 Road, Songshan Lake
Hi-tech Industrial Development Zone, Dongguan City,
Guangdong Pr., China.

Telephone: +86-769- 8507 5888

Fax: +86-769- 8507 5898

Test Site 2:

Company name: Guangdong Dongguan Quality Supervision Testing Center

Address: No.2 South Industry Road, Dongguan Songshan Lake
Sci.&Tech. Industrial Park, Guangdong Province, China

Telephone: +86 769 2307 1111

Fax: +86 769 2307 7221

Standard	Test Item	Test Site
EN IEC 55015:2019/A11:2020	Conducted Disturbance at the electric power supply interface	N/A
	Conducted Disturbance at wired network interfaces other than powersupply	N/A
	Conducted Disturbance at local wired ports other than electrical power supply interface	N/A
	Radiated Disturbance (30MHz to 1GHz)	1
	Magnetic Disturbance (9KHz to 30MHz)	1
EN 61000-4-2:2009	Electrostatic Discharge	1
EN 61000-4-3:2006 +A1:2008+A2: 2010	RF electromagnetic field	2

2. SUMMARY OF TEST RESULTS				
Test procedures according to the technical standards:				
Emission				
Standard	Test Item	Clause	Judgment	Remark
EN IEC 55015:2019/A11:2020	Conducted Disturbance at the electric power supply interface	4.3.1	N/A	
	Conducted Disturbance at wired network interfaces other than powersupply	4.3.2	N/A	
	Conducted Disturbance at local wired ports other than electrical power supply interface	4.4	N/A	
	Radiated Disturbance (30MHz to 1GHz)	4.5.3	PASS	
	Magnetic Disturbance (9KHz to 30MHz)	4.5.2	PASS	
Immunity (EN61547:2009)				
Section	Test Item	Clause	Judgment	Performance Criteria
EN 61000-4-2:2009	Electrostatic Discharge	5.2	PASS	B
EN 61000-4-3:2006 +A1:2008+A1:2010	RF electromagnetic field	5.3	PASS	A
NOTE: (1) "N/A" denotes test is not applicable in this Test Report				

2.1 MEASUREMENT UNCERTAINTY

The reported uncertainty of measurement $y \pm U$ where expanded uncertainty U is based on a standard uncertainty multiplied by a coverage factor of $k=2$ providing a level of confidence of approximately 95 %.

A. Conducted Measurement :

Test Site	Method	Measurement Frequency Range	U · (dB)	NOTE
Test Site 1	ANSI	9 KHz ~ 30MHz	3.19	

B. Conducted Disturbance at Control Terminals :

Test Site	Method	Measurement Frequency Range	U · (dB)	NOTE
Test Site 2	ANSI	9 KHz ~ 30MHz	3.19	

C. Magnetic Disturbance (9KHz to 30MHz) t :

Test Site	Method	Measurement Frequency Range	U · (dB)	NOTE
Test Site 1	ANSI	9KHz ~ 30MHz	2.54	

D. Radiated Disturbance (30MHz to 1GHz) :

Test Site	Method	Measurement Frequency Range	Ant. H / V	U · (dB)	NOTE
Test Site 1	ANSI	30MHz ~ 200MHz	V	3.69	
		30MHz ~ 200MHz	H	3.69	
		200MHz ~ 1,000MHz	V	3.67	
		200MHz ~ 1,000MHz	H	3.67	

2.2 DESCRIPTION OF TEST MODES

To investigate the maximum EMI emission characteristics generates from EUT, the test system was pre-scanning tested base on the consideration of following EUT operation mode or test configuration mode which possible have effect on EMI emission level. Each of these EUT operation mode(s) or test configuration mode(s) mentioned above was evaluated respectively.

Pre-scan mode	
Mode 1	N/A

Final-scan mode	
Mode 1	Normal Operation

2.3 BLOCK DIGRAM SHOWING THE CONFIGURATION OF SYSTEM TESTED

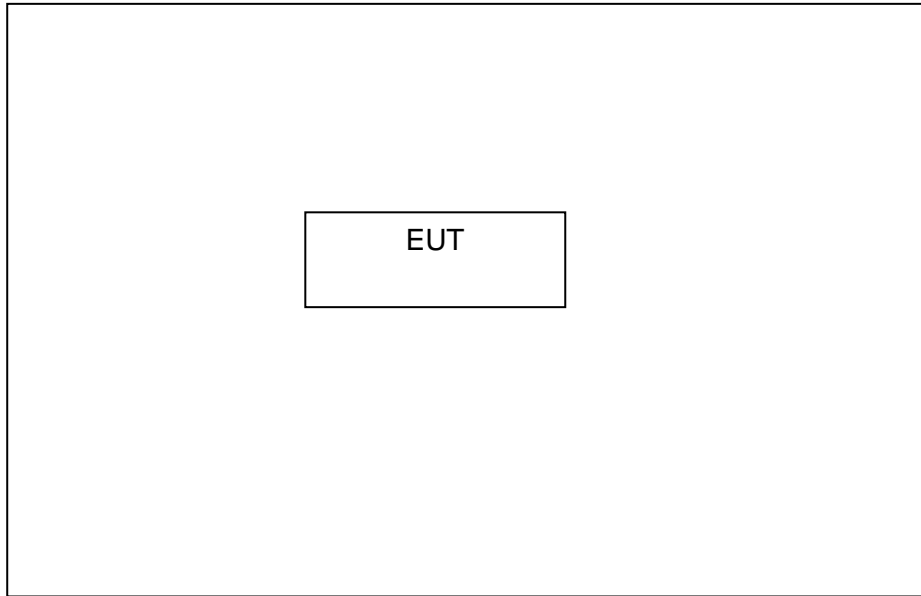

The EUT has been tested as an independent unit together with other necessary accessories or support units. The following support units or accessories were used to form a representative test configuration during the tests.

Item	Equipment	Specification
E-1	N/A	N/A

Item	Type of cable
C-1	N/A

3. EMISSION TEST

3.1 Conducted Disturbance at Mains Terminals

3.1.1 LIMIT OF CONDUCTED EMISSION(MAINS PORT) (Frequency Range 9KHz-30MHz)

FREQUENCY (MHz)	(dBuV)	
	Quasi-peak	Average
0.009-0.05	110	--
0.05-0.15	90-80	--
0.15 -0.5	66 - 56 *	56 - 46 *
0.50 -5.0	56.00	46.00
5.0 -30.0	60.00	50.00

Note:

- (1) The tighter limit applies at the band edges.
- (2) The limit of " * " marked band means the limitation decreases linearly with the logarithm of the frequency in the range.
- (3) The test result calculated as following:

Measurement Value = Reading Level + Correct Factor

Correct Factor = Insertion Loss + Cable Loss + Attenuator Factor (if use)

Margin Level = Measurement Value - Limit Value

The following table is the setting of the receiver

Receiver Parameters	Setting
Attenuation	10 dB
Start Frequency	0.009 MHz
Stop Frequency	30 MHz
IF Bandwidth	200Hz (from 9kHz to 150kHz) and 9kHz (from 150kHz to 30MHz).

3.1.2 MEASUREMENT INSTRUMENTS LIST

Item	Instr.Code	Kind of Equipment	Manufacturer	Type No.	Serial No.	Calibrated until
1	AN-E010	L.I.S.N	SCHWARZBECK	NSLK 8127	8127-669	2021-05-27
2	AN-E028	TRANSIENT LIMITER	CYBERTEK	EM5010A	E1950100113	2021-05-23
3	AN-E022	RF Cable	N/A	ZT06S-BNCJ-NJ-7.5M	19044020	2021-05-23
4	AN-E020	EMI Test Receiver	ROHDE&SCHWARZ	ESCI	101358	2021-05-23
5	AN-E058	1# Shielded Room	chengyu	8m*4m*3.3m	N/A	2022-05-06
6	AN-E046	Test Software	Farad	EZ-EMC Ver:ANCI-8A1	N/A	N/A

Remark: " N/A" denotes No Model No. , Serial No. or No Calibration specified.

3.1.3 TEST PROCEDURE

- a. The EUT was placed 0.4 meters from the horizontal ground plane with EUT being connected to the power mains through a line impedance stabilization network (LISN). All other support equipments powered from additional LISN(s). The LISN provide 50 Ohm/ 50uH of coupling impedance for the measuring instrument.
- b. Interconnecting cables that hang closer than 40 cm to the ground plane shall be folded back and forth in the center forming a bundle 30 to 40 cm long.
- c. I/O cables that are not connected to a peripheral shall be bundled in the center. The end of the cable may be terminated, if required, using the correct terminating impedance. The overall length shall not exceed 1 m.
- d. LISN at least 80 cm from nearest part of EUT chassis.
- e. For the actual test configuration, please refer to the related Item –EUT Test Photos.

3.1.4 DEVIATION FROM TEST STANDARD

No deviation

3.1.5 TEST SETUP

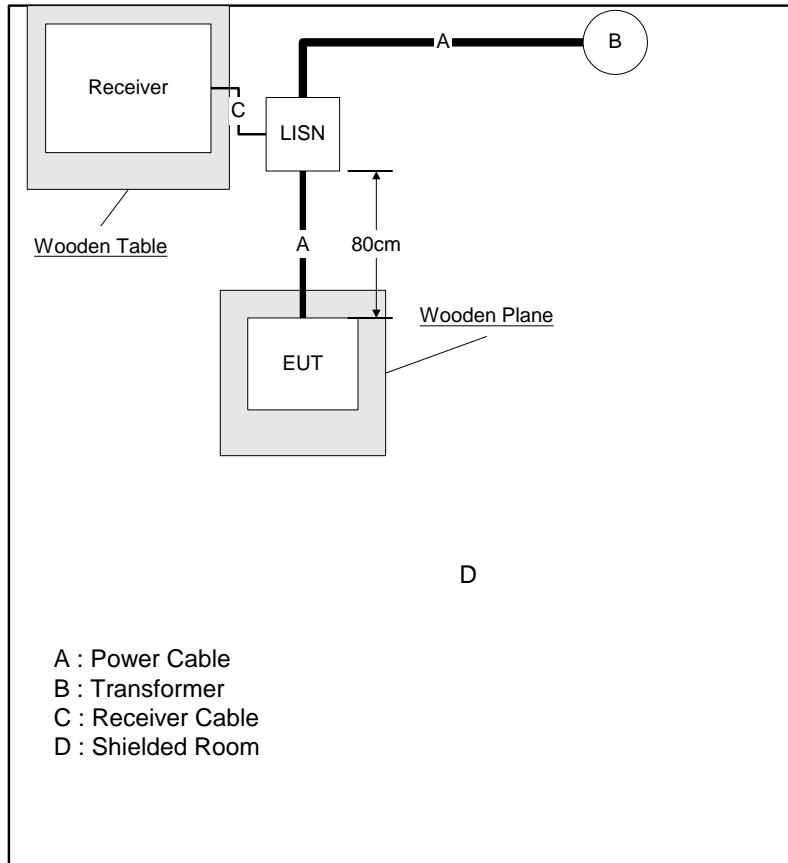

3.1.6 EUT OPERATING CONDITIONS

The EUT exercise program used during radiated and/or conducted emission measurement was designed to exercise the various system components in a manner similar to a typical use.

3.1.7 TEST RESULTS

EUT:	/	Model No.:	/
Temperature:	/	Relative Humidity:	/
Pressure:	/	Test Power :	/
Test Mode :	/		

Remark:

- (1) Reading in which marked as QP means measurements by using Quasi-Peak Detector ,and AV means measurements by using Average Detector.
- (2) All readings are QP Mode value unless otherwise stated AVG in column of 『Note』 . If the QP Mode Measured value compliance with the QP Limits and lower than AVG Limits, the EUT shall be deemed to meet both QP & AVG Limits and then only QP Mode was measured, but AVG Mode didn't perform. In this case, a “ * ” marked in AVG Mode column of Interference Voltage Measured.
- (3) Measuring frequency range from 9KHz to 30MHz.
- (4) This test is not applicable for DC input products.

3.2 Conducted Disturbance at Control Terminals

3.2.1 Specification Limits

Disturbance voltage limits at the Control terminals		
Frequency range	Limits dB(μV)	
	Quasi-peak	Average
0.15MHz to 0.50MHz	84 to 74	74 to 64
0.50MHz to 30MHz	74	64

Notes:

- (1) The limit for radiated test was performed according to as following: CISPR 15.
- (2) The tighter limit applies at the band edges.

3.2.2 MEASUREMENT INSTRUMENTS LIST

Equipment	Manufacturer	Model No.	Serial No.	Next Cal.
Test Receiver	Rohde & Schwarz	ESCI	100227	2021-09-20
L.I.S.N.	Rohde & Schwarz	ENV216	102543	2021-10-25
Voltage probe	SCHWARZBECK	PK9420	9420-233	2021-11-04

3.2.3 TEST PROCEDURE

- A. The EUT was placed on a non-conductive table 0.8 m above a reference ground plane.
- B. The EUT was placed on a non-conductive support 0.1 m above a reference ground plane.
- C. All power was connected to the EUT through an Artificial Mains Network (AMN).
- D. Conducted common mode disturbance voltage measurements on signal ports were made at the output of the Impedance Stabilization Network (ISN) in accordance with Annex C 4.1.6.2. The ISN was placed 0.8m from the boundary of the EUT and bonded to a reference ground plane.
- E. Conducted common mode disturbance current measurements on signal ports were made with a current probe and externally fitted 150 Ω resistor in accordance with Annex C 4.1.6.3.
- F. Conducted common mode disturbance current measurements on signal ports were made with using a combination of a current probe and capacitive voltage probe in accordance with Annex C 4.1.6.4.

3.2.4 TEST SETUP

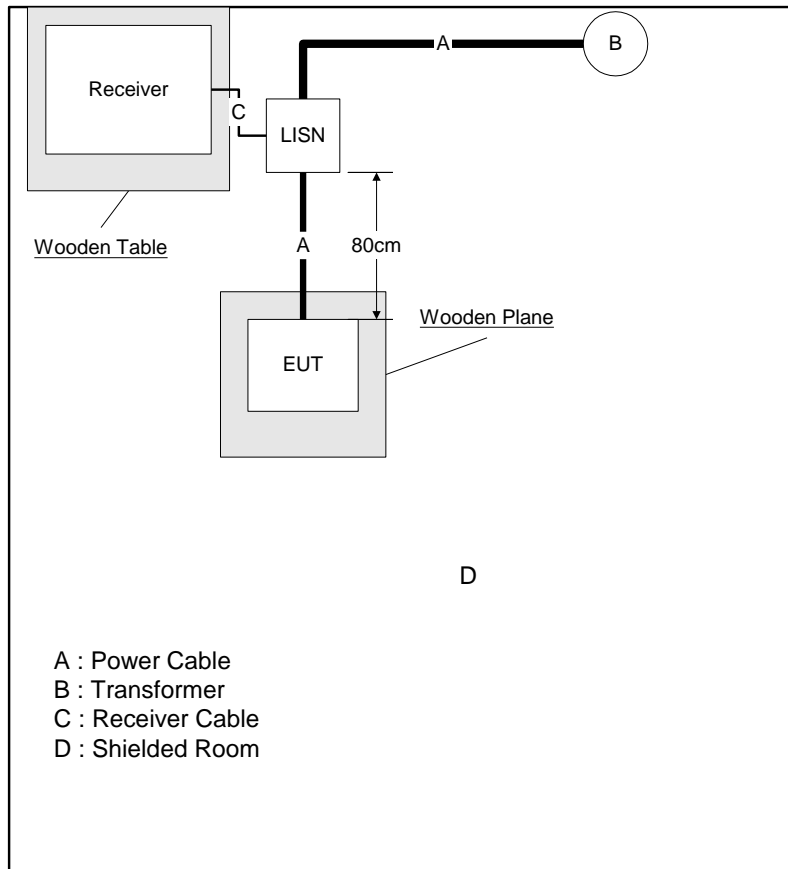

3.2.5 EUT OPERATING CONDITIONS

The EUT exercise program used during radiated and/or conducted emission measurement was designed to exercise the various system components in a manner similar to a typical use.

3.2.6 TEST RESULTS

EUT:	/	Model No.:	/
Temperature:	/	Relative Humidity:	/
Pressure:	/	Test Power :	/
Test Mode :	/		

Note:

1. This test is arranged according to the placement requirements of 3.2.4.
2. Test data see next page
3. This test is not applicable for products without dimming.
4. When the control line and load line are less than 3 meters, this test is not applicable.

3.3 Radiated Disturbance (30MHz to 1000MHz)

3.3.1 LIMITS OF RADIATED EMISSION MEASUREMENT (Below 1000MHz)

FREQUENCY (MHz)	LIMIT (at 3m)
	dBuV/m
30 – 230	40
230 – 1000	47

Notes:

- 1) The limit for radiated test was performed according to as following: CISPR 15.
- 2) The tighter limit applies at the band edges
- 3) Emission level (dBuV/m)=20log Emission level (uV/m).
- 4) Calculation formula: Level=Reading+Factor
Margin=Level-Limit.

3.3.2 MEASUREMENT INSTRUMENTS LIST

3m Radiated Emission Measurement 30MHz-1GHz

Item	Instr.Code	Kind of Equipment	Manufacturer	Type No.	Serial No.	Calibrated until
1	AN-E060	EMI Test Receiver	Rohde & Schwarz	ESCI	100302	2021-05-23
2	AN-E061	Pre-Amplifier	Anritsu	MH648A	M57886	2021-05-23
3	AN-E076	Bilog Antenna	Schwarzbeck	VULB9163	VULB9163-1290	2021-11-15
4	AN-E063	RF Cable	N/A	ZT06S-NJ-NJ-11M	19060398	2021-05-23
5	AN-E064	RF Cable	N/A	ZT06S-NJ-NJ-0.5M	19060400	2021-05-23
6	AN-E065	RF Cable	N/A	ZT06S-NJ-NJ-2.5M	19060404	2021-05-23
7	AN-E056	3m Semi-anechoic Chamber	chengyu	9m*6m*6m	N/A	2022-05-19
8	AN-E069	Test Software	Farad	EZ-EMC Ver:ANCI-2A1	N/A	N/A

Remark: " N/A" denotes No Model No. / Serial No. and No Calibration specified.

3.3.3 TEST PROCEDURE

- a. The measuring distance of at 3 m shall be used for measurements at frequency up to 1GHz. For frequencies above 1GHz, any suitable measuring distance may be used.
- b. The EUT was placed on the top of a rotating table 0.8 meters above the ground at a 3m or 10 meter open area test site. The table was rotated 360 degrees to determine the position of the highest radiation.
- c. The height of the equipment or of the substitution antenna shall be 0.8 m; the height of the test antenna shall vary between 1 m to 4 m. Both horizontal and vertical polarizations of the antenna are set to make the measurement.
- d. The initial step in collecting conducted emission data is a spectrum analyzer peak detector mode pre-scanning the measurement frequency range. Significant peaks are then marked and then Quasi Peak detector mode re-measured.
- e. If the Peak Mode measured value compliance with and lower than Quasi Peak Mode Limit, the EUT shall be deemed to meet QP Limits and then no additional QP Mode measurement performed.
- f. For the actual test configuration, please refer to the related Item –EUT Test Photos.

3.3.4 DEVIATION FROM TEST STANDARD

No deviation

3.3.5 TEST SETUP

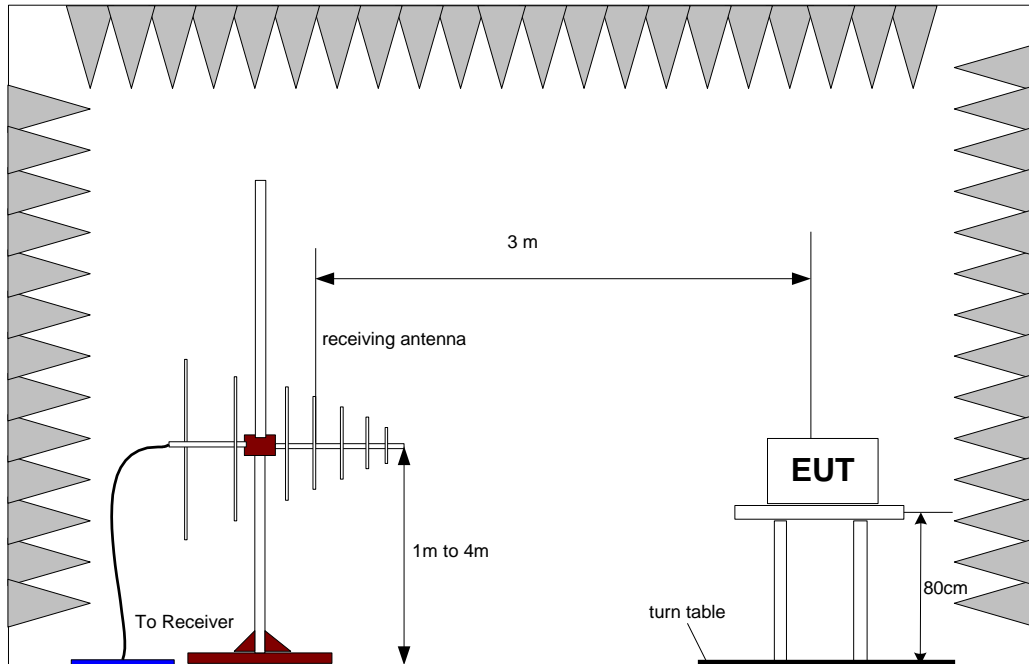

3.3.6 EUT OPERATING CONDITIONS

The EUT tested system was configured as the statements of 3.1.6 Unless otherwise a special operating condition is specified in the follows during the testing.

3.3.7 TEST RESULTS

EUT:	Keychain light	Model No.:	K6R
Temperature:	23°C	Relative Humidity:	57%
Pressure:	1008 hPa	Test Power :	DC 3.7V
Test Mode :	Normal Operation		

Remark:

- (1) Reading in which marked as QP or Peak means measurements by using are Quasi-Peak Detector or Peak Detector.
- (2) All readings are Peak unless otherwise stated QP in column of 『Note』 . Peak denotes that the Peak reading compliance with the QP Limits and then QP Mode measurement didn't perform.
- (3) Measuring frequency range from 30MHz to 1GHz.
- (4) If the peak scan value lower limit more than 20dB, then this signal data does not show in table.

M/N:	K6R
Op Cond.:	Normal Operation(White Light)
Comment:	DC 3.7V
Test Spec:	Horizontal
Noto:	DisCharging
Detailed results are shown below	



No.	Frequency (MHz)	Reading (dBuV)	Factor (dB/m)	Level (dBuV/m)	Limit (dBuV/m)	Margin (dB)	Det.	Height (cm)	Azimuth (deg)	Remark
1	34.8212	27.89	-17.65	10.24	40.00	-29.76	QP			
2	60.4919	25.99	-15.77	10.22	40.00	-29.78	QP			
3	104.1701	26.04	-16.65	9.39	40.00	-30.61	QP			
4	135.5062	29.89	-18.49	11.40	40.00	-28.60	QP			
5 *	174.7301	31.29	-17.31	13.98	40.00	-26.02	QP			
6	331.3546	29.25	-12.44	16.81	47.00	-30.19	QP			

M/N:	K6R
Op Cond.:	Normal Operation(White Light)
Comment:	DC 3.7V
Test Spec:	Vertical
Noto:	DisCharging
Detailed results are shown below	

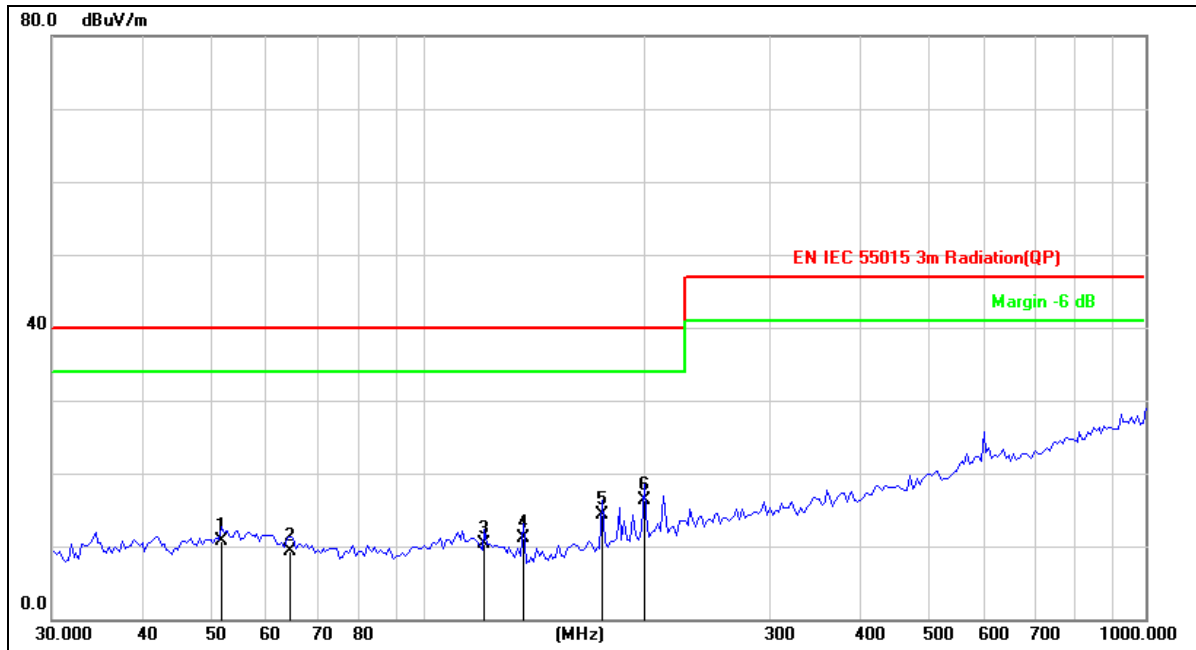

No.	Frequency (MHz)	Reading (dBuV)	Factor (dB/m)	Level (dBuV/m)	Limit (dBuV/m)	Margin (dB)	Det.	Height (cm)	Azimuth (deg)	Remark
1	51.6616	26.38	-15.70	10.68	40.00	-29.32	QP			
2	64.3202	25.88	-16.60	9.28	40.00	-30.72	QP			
3	119.8556	27.25	-16.90	10.35	40.00	-29.65	QP			
4	135.5062	29.57	-18.49	11.08	40.00	-28.92	QP			
5	174.7301	31.62	-17.31	14.31	40.00	-25.69	QP			
6 *	199.2855	32.46	-16.11	16.35	40.00	-23.65	QP			

M/N:	K6R
Op Cond.:	Normal Operation(Red Light)
Comment:	DC 3.7V
Test Spec:	Horizontal
Noto:	DisCharging
Detailed results are shown below	



No.	Frequency (MHz)	Reading (dBuV)	Factor (dB/m)	Level (dBuV/m)	Limit (dBuV/m)	Margin (dB)	Det.	Height (cm)	Azimuth (deg)	Remark
1	55.9026	26.45	-15.68	10.77	40.00	-29.23	QP			
2	61.0245	26.08	-15.90	10.18	40.00	-29.82	QP			
3	110.7627	26.12	-16.24	9.88	40.00	-30.12	QP			
4	135.5062	28.74	-18.49	10.25	40.00	-29.75	QP			
5 *	174.7301	32.46	-17.31	15.15	40.00	-24.85	QP			
6	199.2855	30.50	-16.11	14.39	40.00	-25.61	QP			

M/N:	K6R
Op Cond.:	Normal Operation(Red Light)
Comment:	DC 3.7V
Test Spec:	Vertical
Nota:	DisCharging
Detailed results are shown below	

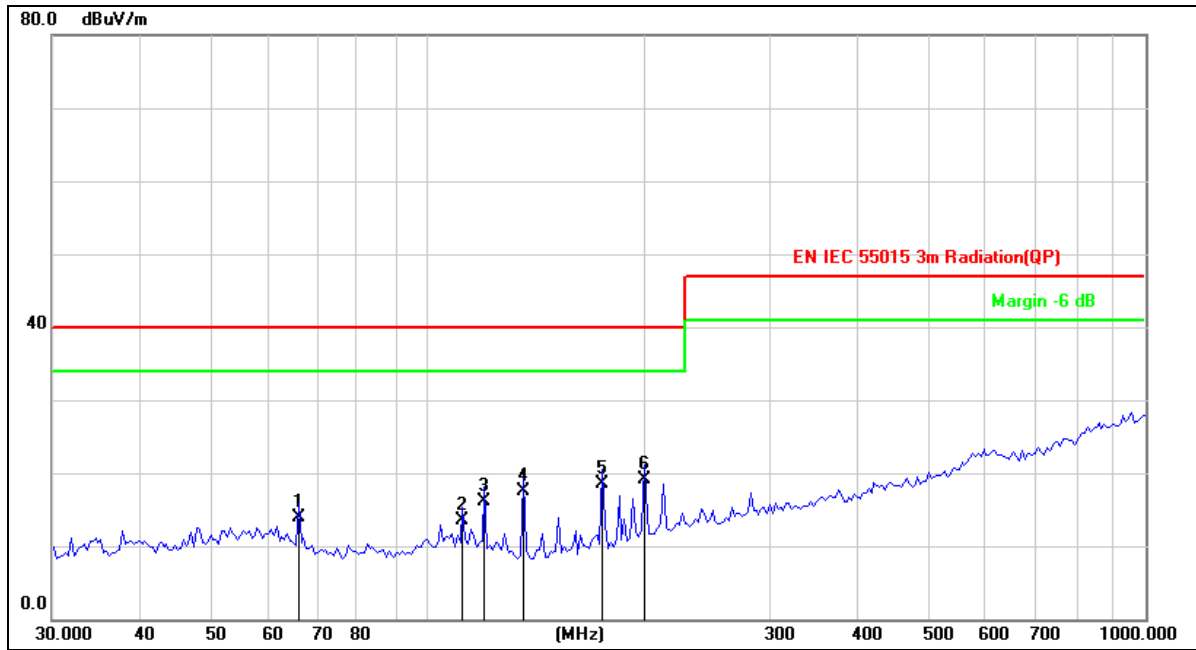

No.	Frequency (MHz)	Reading (dBuV)	Factor (dB/m)	Level (dBuV/m)	Limit (dBuV/m)	Margin (dB)	Det.	Height (cm)	Azimuth (deg)	Remark
1	66.0342	30.90	-16.98	13.92	40.00	-26.08	QP			
2	111.7380	29.74	-16.32	13.42	40.00	-26.58	QP			
3	119.8556	33.08	-16.90	16.18	40.00	-23.82	QP			
4	135.5062	35.90	-18.49	17.41	40.00	-22.59	QP			
5	174.7301	35.87	-17.31	18.56	40.00	-21.44	QP			
6 *	199.2855	35.16	-16.11	19.05	40.00	-20.95	QP			

3.4 measurement emission measurement

3.4.1 MEASUREMENT INSTRUMENTS LIST

Item	Instr.Code	Kind of Equipment	Manufacturer	Type No.	Serial No.	Calibrated until
1	AN-E013	3 Loop Antenna	Da Ze	ZN30401	2944A09491	2021-05-23
3	AN-E026	RF Cable	N/A	ZT06S-NJ-NJ-3M	19044021	2021-05-23
4	AN-E020	EMI Test Receiver	ROHDE&SCHWARZ	ESCI	101358	2021-05-23
5	AN-E058	1# Shielded Room	chengyu	8m*4m*3.3m	N/A	2022-05-06
6	AN-E046	Test Software	Farad	EZ-EMC Ver:ANCI-8A1	N/A	N/A

Remark: " N/A" denotes No Model No. / Serial No. and No Calibration specified.

3.4.2 LIMITS OF MAGNETIC EMISSION MEASUREMENT

Frequency Range	Limits for loop diameter dB(A) ⁽¹⁾
	2m
9KHz-70KHz	88
70KHz-150KHz	88-58
150KHz-3.0MHz	58-22
3.0MHz-30MHz	22

3.4.3 LARGE LOOP ANTENNA SETUP DIAGRAM

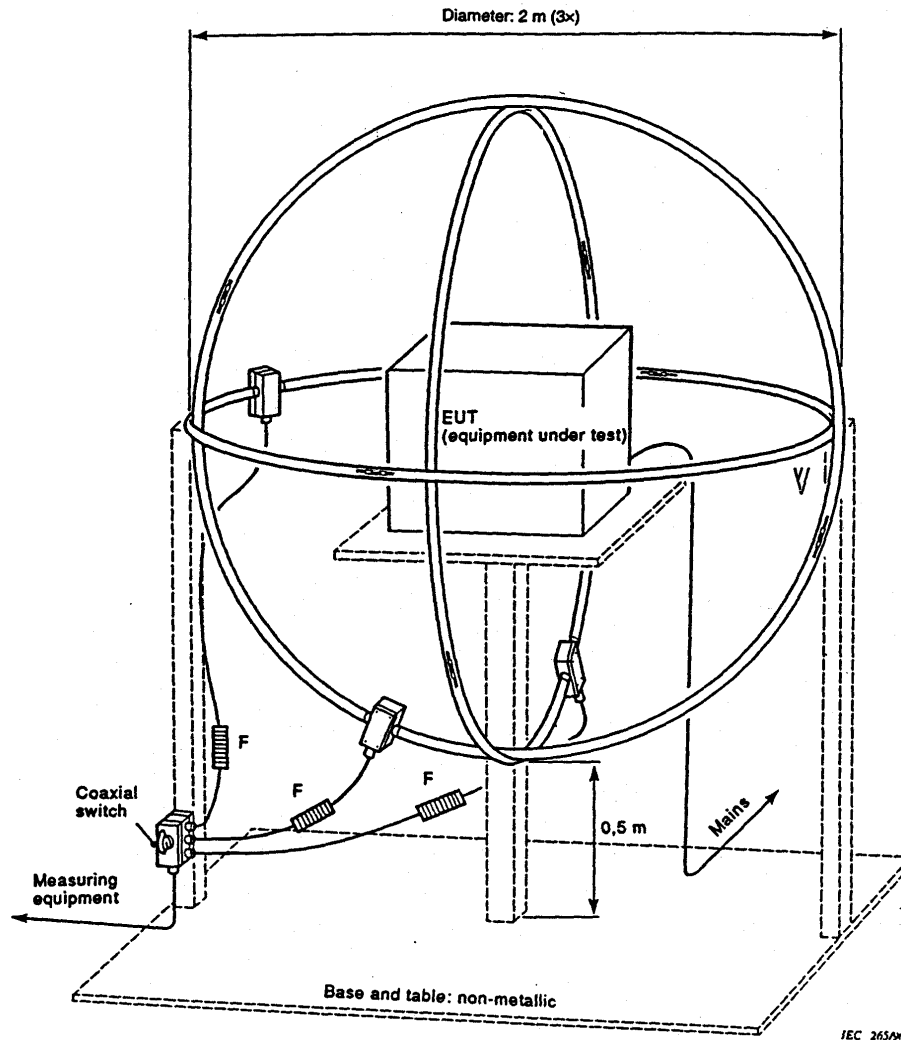

3.4.4 OPERATING CONDITIONS OF THE EUT

The exercise program used during conducted emission measurement was designed to exercise the EUT in a manner similar to a typical use. The exercise sequence is listed as below:

1. Setup the EUT and simulators as shown on 3.3.
2. Turn on the power of all equipments.
3. Start test.

3.4.5 MAGNETIC EMISSION DATA

The quasi-peak limits of the magnetic component of the radiated electromagnetic disturbance field strength in the frequency range **9kHz to 30MHz** measured as a current in 2m, loop antennas around the lighting equipment.

The measurement range of radiated emission, which is from **9kHz to 30MHz**, was investigated. All readings are quasi-peak values with a proper resolution Bandwidth. The initial step in collecting radiated emission data is a spectrum analyzer peak scans of the measurement range for all the test modes and then use test receiver for final measurement. Then the worst modes were reported the following data pages.

3.4.6 TEST RESULTS

EUT:	Keychain light	Model No.:	K6R
Temperature:	23°C	Relative Humidity:	57%
Pressure:	1008 hPa	Test Power :	DC 3.7V
Test Mode :	Normal Operation		

Remarks :

1. Measurement = Reading + Factor
2. Over Limit (Margin Value)=Measurement level-Limit value.

M/N:	K6R
Op Cond.:	Normal Operation(White Light)
Comment:	DC 3.7V
Test Spec.:	X (2m)
Noto:	DisCharging
Detailed results are shown below	

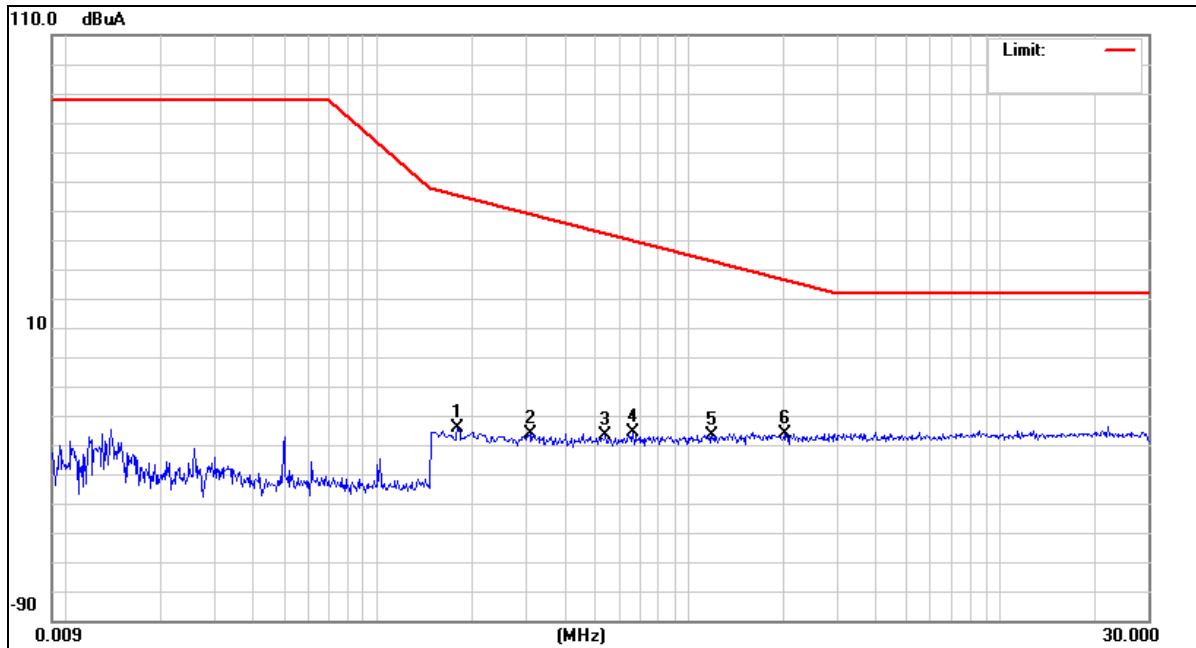

No.	Frequency (MHz)	Reading Level(dBuA)	Factor (dB)	Measurement(dBuA)	Limit (dBuA)	Over (dB)	Detector	Comment
1	0.1819	-25.80	1.61	-24.19	55.56	-79.75	peak	
2	0.3099	-27.90	1.57	-26.33	49.18	-75.51	peak	
3	0.5420	-28.46	1.59	-26.87	42.49	-69.36	peak	
4	0.6660	-27.14	1.55	-25.59	40.02	-65.61	peak	
5	1.1978	-28.22	1.59	-26.63	32.99	-59.62	peak	
6 *	2.0459	-28.06	1.84	-26.22	26.58	-52.80	peak	

M/N:	K6R
Op Cond.:	Normal Operation(White Light)
Comment:	DC 3.7V
Test Spec.:	Y (2m)
Noto:	DisCharging
Detailed results are shown below	

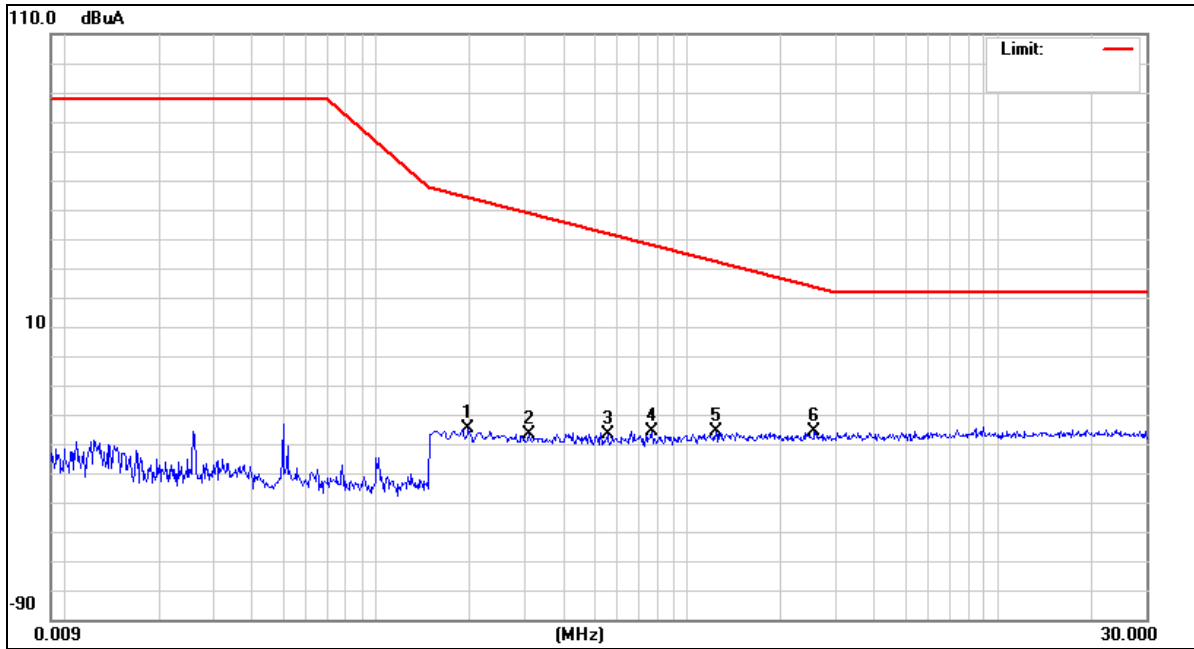

No.	Frequency (MHz)	Reading Level(dBuA)	Factor (dB)	Measurement(dBuA)	Limit (dBuA)	Over (dB)	Detector	Comment
1	0.1980	-26.28	1.61	-24.67	54.55	-79.22	peak	
2	0.3099	-28.30	1.57	-26.73	49.18	-75.91	peak	
3	0.5580	-28.18	1.60	-26.58	42.14	-68.72	peak	
4	0.7700	-27.44	1.46	-25.98	38.28	-64.26	peak	
5	1.2459	-27.25	1.60	-25.65	32.52	-58.17	peak	
6 *	2.5698	-27.55	1.82	-25.73	23.85	-49.58	peak	

M/N:	K6R
Op Cond.:	Normal Operation(White Light)
Comment:	DC 3.7V
Test Spec.:	Z (2m)
Noto:	DisCharging
Detailed results are shown below	

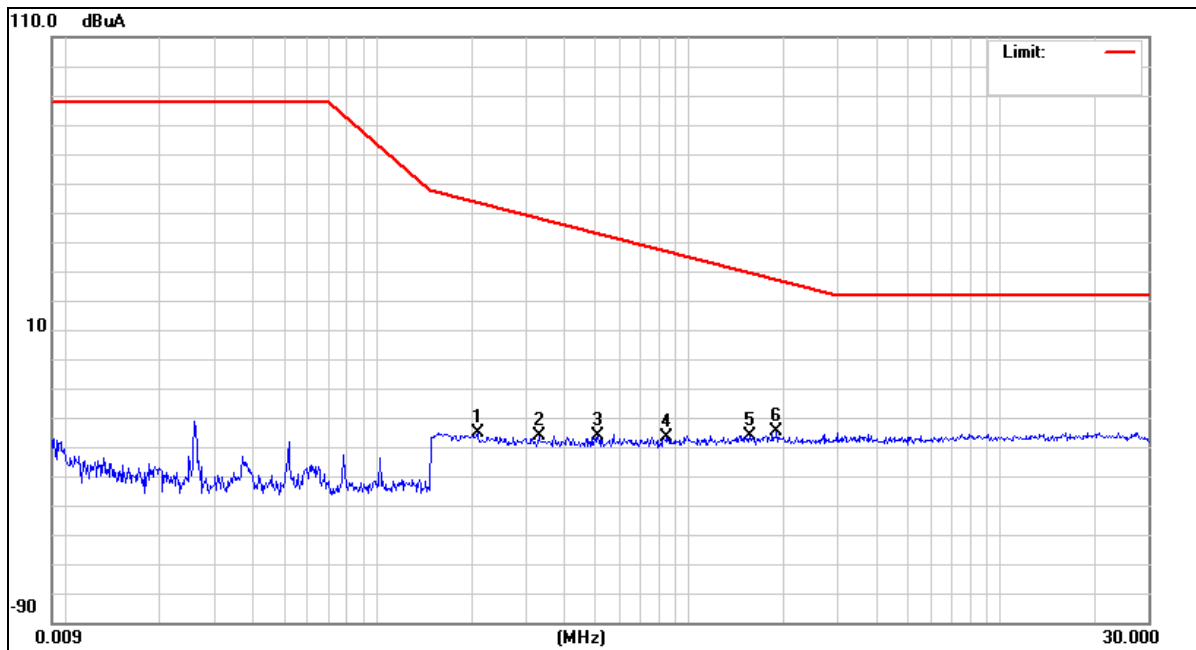

No.	Frequency (MHz)	Reading Level(dBuA)	Factor (dB)	Measurement(dBuA)	Limit (dBuA)	Over (dB)	Detector	Comment
1	0.2099	-26.90	1.61	-25.29	53.85	-79.14	peak	
2	0.3300	-27.67	1.56	-26.11	48.43	-74.54	peak	
3	0.5140	-27.73	1.58	-26.15	43.12	-69.27	peak	
4	0.8578	-28.01	1.46	-26.55	36.99	-63.54	peak	
5	1.5700	-27.73	1.71	-26.02	29.75	-55.77	peak	
6 *	1.9258	-26.74	1.82	-24.92	27.31	-52.23	peak	

4. EMC IMMUNITY TEST

4.1 STANDARD COMPLIANCE/SERVIRITY LEVEL/CRITERIA

Tests Standard No.	Test Specification	Test Mode Test Ports	Perform. Criteria	Remark
1. ESD IEC/EN 61000-4-2	8KV air discharge 4KV contact discharge	Direct Mode	B	PASS
	4KV HCP discharge 4KV VCP discharge	Indirect Mode	B	PASS
2. RS IEC/EN 61000-4-3	80 MHz to 1000 MHz 3V/m(rms), 1 KHz, 80%, AM modulated	Enclosure	A	PASS

* Remark:

(1) "N/A": denotes test is not applicable in this Test Report.

4.2 GENERAL PERFORMANCE CRITERIA

According to **EN61547:2009** standard, the general performance criteria as following:

Criterion A	During the test no change of the luminous intensity shall be observed and the regulating control, if any shall operate during the test as intended.
Criterion B	During the test the luminous intensity may change to any value. After the test the luminous intensity shall be restored to its initial value within 1 min. Regulating controls need not function during the test, but after the test the mode of the control shall be the same as before the test provided that during the test no mode changing commands were given.
Criterion C	During and after the test any change of the luminous intensity is allowed and the lamps(s) may be extinguished. After the test, within 30 min, all function shall return to normal if necessary by temporary interruption of the mains supply and/or operating the regulating control. Additional requirement for lighting equipment incorporating a starting device.: After the test the lighting equipment is switched off. After half an hour it is switched on again. The lighting equipment shall start and operate as intended.

4.3 GENERAL PERFORMANCE CRITERIA TEST SETUP

The EUT tested system was configured as the statements of **3.1.6** Unless otherwise a special operating condition is specified in the follows during the testing.

4.4 ESD TESTING

4.4.1 TEST SPECIFICATION

Basic Standard:	IEC/EN 61000-4-2
Discharge Impedance:	330 ohm / 150 pF
Required Performance	B
Discharge Voltage:	Air Discharge: 2kV/4kV/8kV (Direct) Contact Discharge: 2kV/4kV (Direct/Indirect)
Polarity:	Positive & Negative
Number of Discharge:	Air Discharge: min. 10 times at each test point Contact Discharge: min. 200 times in total
Discharge Mode:	Single Discharge
Discharge Period:	1 second minimum

4.4.2 MEASUREMENT INSTRUMENTS

Item	Instr.Code	Kind of Equipment	Manufacturer	Type No.	Serial No.	Calibrated until
1	AN-E002	ESD Simulator	Prima	ESD61002B	PR13012530	2021-05-23

Remark: " N/A" denotes No Model No. / Serial No. and No Calibration specified.

4.4.3 TEST PROCEDURE

The test generator necessary to perform direct and indirect application of discharges to the EUT in the following manner:

- a. Contact discharge was applied to conductive surfaces and coupling planes of the EUT. During the test, it was performed with single discharges. For the single discharge time between successive single discharges was at least 1 second. The EUT shall be exposed to at least 200 discharges, 100 each at negative and positive polarity, at a minimum of four test points. One of the test points shall be subjected to at least 50 indirect discharges to the center of the front edge of the horizontal coupling plane. The remaining three test points shall each receive at least 50 direct contact discharges. If no direct contact test points are available, then at least 200 indirect discharges shall be applied in the indirect mode. Test shall be performed at a maximum repetition rate of one discharge per second.
 - Vertical Coupling Plane (VCP):
The coupling plane, of dimensions 0.5m x 0.5m, is placed parallel to, and positioned at a distance 0.1m from, the EUT, with the Discharge Electrode touching the coupling plane. The four faces of the EUT will be performed with electrostatic discharge.
 - Horizontal Coupling Plane (HCP):
The coupling plane is placed under to the EUT. The generator shall be positioned vertically at a distance of 0.1m from the EUT, with the Discharge Electrode touching the coupling plane. The four faces of the EUT will be performed with electrostatic discharge.
- b. Air discharges at insulation surfaces of the EUT. It was at least ten single discharges with positive and negative at the same selected point.
- c. For the actual test configuration, please refer to the related Item –EUT Test Photos.

4.4.4 DEVIATION FROM TEST STANDARD

No deviation

4.4.5 TEST SETUP

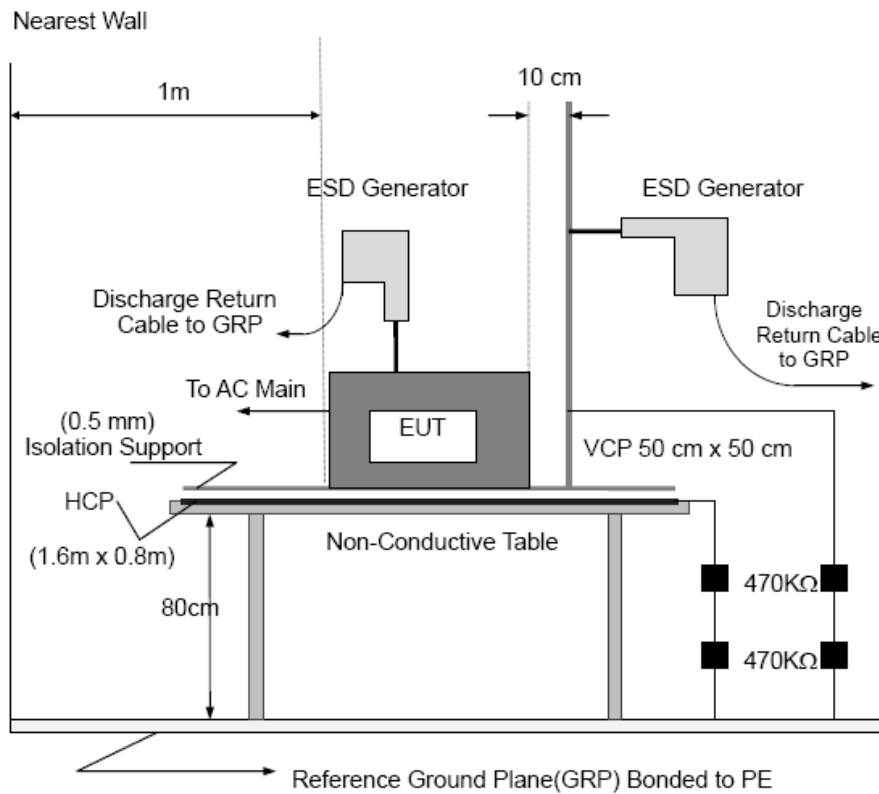

Note:

TABLE-TOP EQUIPMENT

The configuration consisted of a wooden table 0.8 meters high standing on the Ground Reference Plane. The GRP consisted of a sheet of aluminum at least 0.25mm thick, and 2.5 meters square connected to the protective grounding system. A Horizontal Coupling Plane (1.6m x 0.8m) was placed on the table and attached to the GRP by means of a cable with 940k total impedance. The equipment under test, was installed in a representative system as described in section 7 of IEC /EN 61000-4-2, and its cables were placed on the HCP and isolated by an insulating support of 0.5mm thickness. A distance of 1-meter minimum was provided between the EUT and the walls of the laboratory and any other metallic structure.

FLOOR-STANDING EQUIPMENT

The equipment under test was installed in a representative system as described in section 7 of IEC/EN 61000-4-2, and its cables were isolated from the Ground Reference Plane by an insulating support of 0.1-meter thickness. The GRP consisted of a sheet of aluminum that is at least 0.25mm thick, and 2.5meters square connected to the protective grounding system and extended at least 0.5 meters from the EUT on all sides.

4.4.6 TEST RESULTS

Mode	Air Discharge								Contact Discharge							
	2KV		4KV		8KV		12KV		2KV		4KV		6KV		8KV	
Location	P	N	P	N	P	N	P	N	P	N	P	N	P	N	P	N
1	--	--	A	A	B	B	--	--	--	--	--	--	--	--	--	--
2	--	--	--	--	--	--	--	--	A	A	B	B	--	--	--	--
3	-	--	--	--	--	--	--	--	--	--	--	--	--	--	--	--
4	--	--	--	--	--	--	--	--	--	--	--	--	--	--	--	--
5	--	--	--	--	--	--			--	--	--	--	--	--	--	--
6	-	--	--	--	--	--	--	--	--	--	--	--	--	--	--	--
7	--	--	--	--	--	--	--	--	--	--	--	--	--	--	--	--
8	--	--	--	--	-	--	--	--	--	--	--	--	--	--	--	--
9	-	--	--	--	--	--	--	--	--	--	--	--	--	--	--	--
Criteria	B								B							
Result	B								B							
Judgment	PASS								PASS							

Mode	HCP Discharge								VCP Discharge							
	2KV		4KV		6KV		8KV		2KV		4KV		6KV		8KV	
Location	P	N	P	N	P	N	P	N	P	N	P	N	P	N	P	N
1	-	--	A	A	--	--	--	--	-	--	A	A	--	--	--	--
2	--	--	A	A	--	--	--	--	--	--	A	A	--	--	--	--
3	--	--	A	A	-	--	--	--	--	--	A	A	-	--	--	--
4	-	--	A	A	--	--	--	--	--	--	A	A	--	--	--	--
Criteria	B								B							
Result	A								A							
Judgment	PASS								PASS							

Note:

- 1) P/N denotes the Positive/Negative polarity of the output voltage.
- 2) Test condition:
 Direct discharges: Minimum 20 times (Positive/Negative) at each point.
 Air discharges / Indirect (HCP/VCP): Minimum 20 times (Positive/Negative) at each point.
- 3) Test location(s) in which discharge (Air and contact discharge) to be described as following
- 4) The Indirect (HCP/VCP) discharges description of test point as following:
 1.left side 2.right side 3.front side 4.rear side
- 5) N/A - denotes test is not applicable in this test report

Test Point:

No	Description	No	Description	No	Description
1	Output 4Points	4			
2	Non-metal 5Points	5			
3	GAP 5Points	6			

4.5 RS TESTING

4.5.1 TEST SPECIFICATION

Basic Standard:	IEC/EN 61000-4-3
Required Performance	A
Frequency Range:	80 MHz - 1000 MHz
Field Strength:	3 V/m
Modulation:	1kHz Sine Wave, 80%, AM Modulation
Frequency Step:	1 % of fundamental
Polarity of Antenna:	Horizontal and Vertical
Test Distance:	3 m
Antenna Height:	1.5 m
Dwell Time:	at least 3 seconds

4.5.2 MEASUREMENT INSTRUMENTS

Equipment	Manufacturer	Model No.	Serial No.	Next Cal.
Signal Generator	Agilent	N5171B-50B	MY53050160	2021-10-11
Amplifier	A&R	150W1000M3	313157	2021-09-20
Amplifier	A&R	50SIG6M1	0342835	2021-09-20
Power Meter	Boonton	4232A	15102	2021-09-20
Isotropic Field Probe	A&R	FL7006	0342652	2021-10-11
Log-periodic Antenna	SCHWARZBECK	STLP 9128E	9128E-012	2021-06-16
Microwave log-periodic antenna	SCHWARZBECK	STLP 9149	9149.222	2021-10-11

Remark: " N/A" denotes No Model No. / Serial No. and No Calibration specified.

4.5.3 TEST PROCEDURE

The EUT and support equipment, which are placed on a table that is 0.8 meter above ground and the testing was performed in a fully-anechoic chamber.

The testing distance from antenna to the EUT was 3 meters.

The other condition as following manner:

- a. The field strength level was 3V/m.
- b. The frequency range is swept from 80 MHz to 1000 MHz, with the signal 80%amplitude modulated with a 1kHz sine wave. The rate of sweep did not exceed 1.5x 10⁻³ decade/s. Where the frequency range is swept incrementally, the step size was 1% of fundamental.
- c. The dwell time at each frequency shall be not less than the time necessary for the EUT to be able to respond.
- d. The test was performed with the EUT exposed to both vertically and horizontally polarized fields on each of the four sides.
- e. For the actual test configuration, please refer to the related Item –EUT Test Photos.

4.5.4 DEVIATION FROM TEST STANDARD

No deviation

4.5.5 TEST SETUP

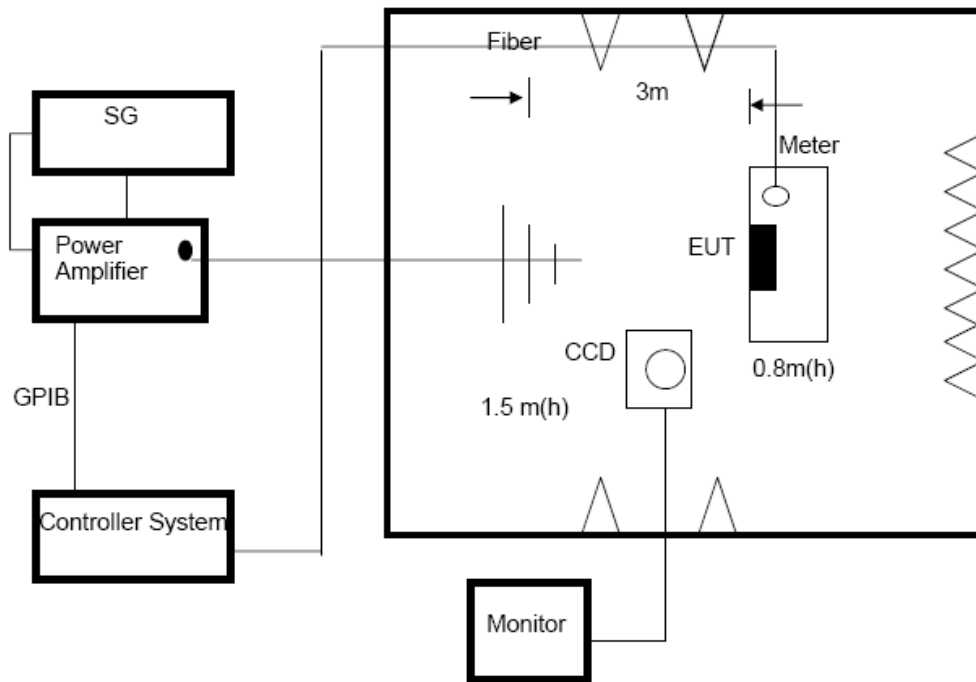

Note:

TABLE-TOP EQUIPMENT

The EUT installed in a representative system as described in section 7 of IEC/EN 61000-4-3 was placed on a non-conductive table 0.8 meters in height. The system under test was connected to the power and signal wire according to relevant installation instructions.

FLOOR-STANDING EQUIPMENT

The EUT installed in a representative system as described in section 7 of IEC/EN 61000-4-3 was placed on a non-conductive wood support 0.1 meters in height. The system under test was connected to the power and signal wire according to relevant installation instructions.

4.5.6 TEST RESULTS

Frequency Range (MHz)	RF Field Position	R.F. Field Strength	Azimuth	Perform. Criteria	Results	Judgment
80MHz - 1000MHz	H / V	3 V/m (rms) AM Modulated 1000Hz, 80%	0	A	A	PASS
			90			
			180			
			270			

Note:

- 1) N/A - denotes test is not applicable in this test report.
- 2) Criteria A: There was no change operated with initial operating during the test.
- 3) Criteria B: The EUT function loss during the test, but self-recoverable after the test.
- 4) Criteria C: The system shut down during the test.

5. ATTACHMENT
5.1 EUT Test Photo

Radiated Measurement Photo



Magnetic Emission Test Photo



ESD Measurement Photo

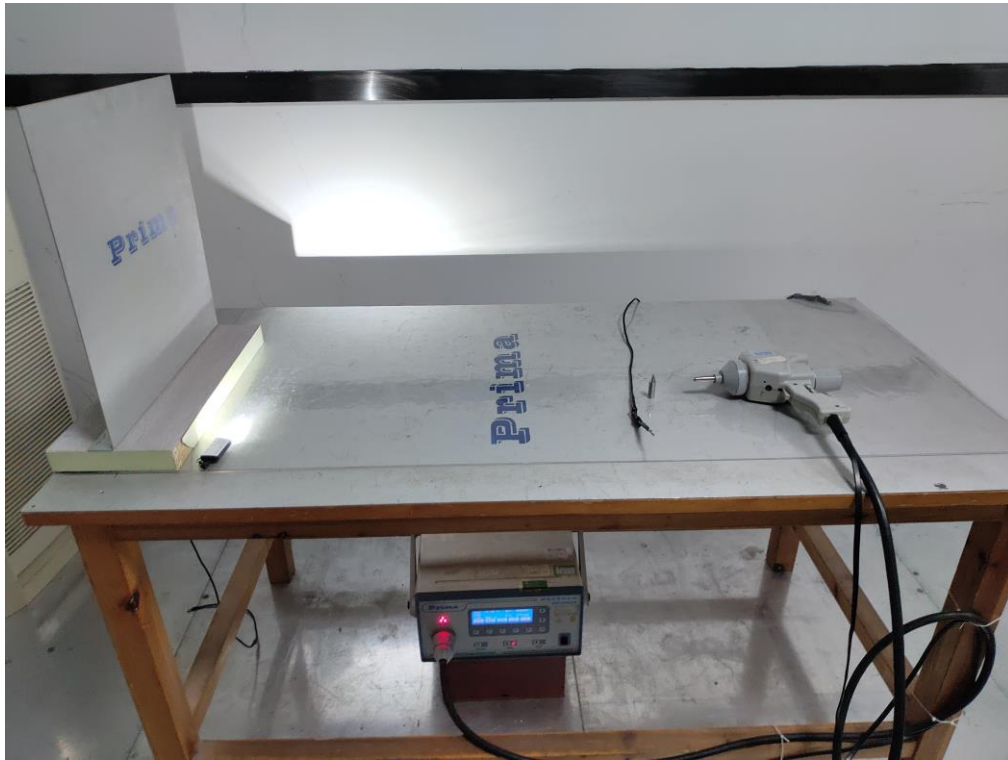

5.2 EUT Photo



Figure 1: Overall view of unit



Figure 2: Overall view of unit



Figure 3: Overall view of unit



Figure 4: Overall view of unit



Figure 5. Overall view of unit

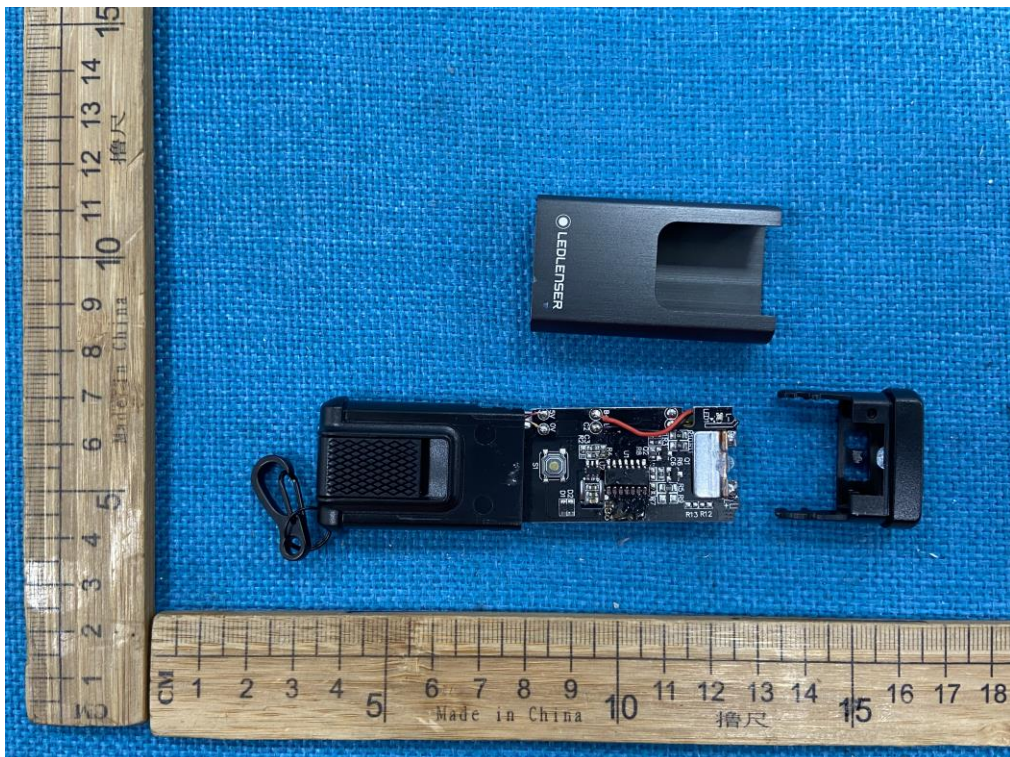

Figure 6. Internal view of unit

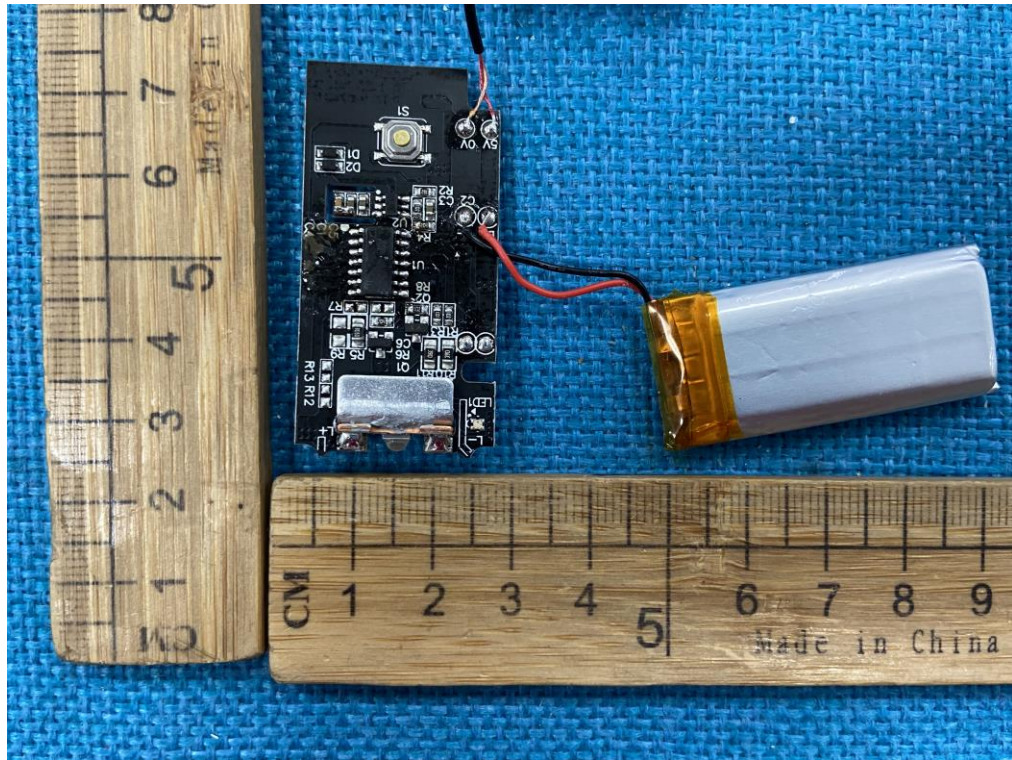

Figure 7: Bottom view of PCB



Figure 8: Bottom view of Top PCB

***** End of Page *****